



IMPORTANT SAFETY INSTRUCTIONS SAVE THESE INSTRUCTIONS

PLEASE READ THE ENTIRE CONTENTS OF THIS MANUAL PRIOR TO INSTALLATION AND OPERATION. BY PROCEEDING WITH LIFT INSTALLATION AND OPERATION YOU AGREE THAT YOU FULLY UNDERSTAND AND COMPREHEND THE FULL CONTENTS OF THIS MANUAL. FORWARD THIS MANUAL TO ALL OPERATORS. FAILURE TO OPERATE THIS EQUIPMENT AS DIRECTED MAY CAUSE INJURY OR DEATH.

Rev. A3 August 2017
P/N 5900030

INSTALLATION AND OPERATION MANUAL

6,000 LB. / 2,722 KG. CAPACITY MID-RISE SCISSOR CAR LIFT

Models:

- MDS-6EXT
- MDS-6EXTF
- MDS-6LP
- MDS-6LPF



RECEIVING

The shipment should be thoroughly inspected as soon as it is received. The signed Bill of Lading is acknowledgment by the shipping carrier as receipt of this product as listed in your invoice as being in a good condition of shipment. If any of these goods listed on this Bill of Lading are missing or damaged, do not accept goods until the shipping carrier makes a notation on the freight bill of the missing or damaged goods. Do this for your own protection.

BE SAFE

Your new lift was designed and built with safety in mind. However, your overall safety can be increased with proper training and thoughtful operation on the part of the operator. DO NOT operate or repair this equipment without reading this manual and the important safety instructions shown inside. Keep this operation manual near the lift at all times. Make sure that ALL USERS read and understand this manual.



1645 Lemonwood Dr.
Santa Paula, CA. 93060, USA
Toll Free 1-800-253-2363
Tel: 1-805-933-9970
Fax: 1-805-933-9160
www.bendpak.com

6,000 Pound Capacity Mid-Rise Scissor Lift

This instruction manual has been prepared especially for you. Your new lift is the product of over 40 years of continuous research, testing, and development; it is the most technically advanced lift on the market today.

READ THIS ENTIRE MANUAL BEFORE INSTALLATION & OPERATION BEGINS!

Record here the lift and power unit information that is located on the serial number data plates on the lift and on the power unit.

Power Unit Model # _____
Power Unit Date Of Mfg. _____
Power Unit Serial # _____
Max Operating Pressure 2,650 PSI

This information is **required** when calling for part or warranty issues.

BP BendPak. Santa Paula, CA USA
www.bendpak.com

| | |
|---|---|
| MODEL NUMBER | |
| | |
| SERIAL NUMBER | |
| | |
| LIFT CAPACITY | DESCRIPTION |
| | |
| VOLTAGE | |
| <input type="checkbox"/> 110-240VAC, 50-60 Hz, 1 Ph | <input type="checkbox"/> 380-415VAC, 50-60 Hz, 3 Ph |
| <input type="checkbox"/> 208-240VAC, 50-60 Hz, 1 Ph | <input type="checkbox"/> 208-440VAC, 50-60 Hz, 3 Ph |
| DATE OF MFG. | |

DANGER!
Disconnect Power Before Servicing
WARRANTY VOID IF DATA PLATE IS REMOVED FR 590951

ERC

Product Warranty

Our comprehensive product warranty means more than a commitment to you; it's also a commitment to the value of your new MDS-6EXT/MDS-6EXTF/MDS-6LP/MDS-6LPF BendPak lift. For full warranty details and to register your new lift, contact your nearest BendPak dealer or visit: www.bendpak.com/support/warranty.

What is not covered under this warranty:

- Any failure that results from purchaser abuse, neglect, or failure to operate, maintain or service product in accordance with instructions provided in the manual(s), supplied.
- Any damage caused by overloading lift beyond rated capacity.
- Items or service normally required to maintain the product; for example, lubricants, oil, and so on.
- Items considered general-wear parts such as rubber pads, lifting cables, and so on unless wear or failure is a direct result of manufacturer defect due to material and/or workmanship.
- Any component damaged in shipment or any failure caused by installing or operating the lift under conditions not in accordance with installation and operation guidelines or damaged by contact with tools or surroundings.
- Motor or pump failure caused by rain, excessive humidity, corrosive environments, or other contaminants.
- Rusted components due to improper maintenance or corrosive environments.
- Cosmetic defects that do not interfere with product functionality.
- Damage due to incorrect voltage or improper wiring.
- Any incidental, indirect, or consequential loss, damage, or expense that may result from any defect, failure or malfunction of the BendPak, Inc. product.
- All electrical components (excluding power unit) are guaranteed for one year against defects in workmanship and/or materials when the lift is installed and used according to specifications.

NOTE:

Every effort has been taken to ensure complete and accurate instructions have been included in this manual, however, possible product updates, revisions and or changes may have occurred since this printing. BendPak Ranger reserves the right to change specifications without incurring any obligation for equipment previously or subsequently sold. Not responsible for typographical errors.

IMPORTANT NOTICE

Do not attempt to install this lift unless you have been trained on basic automotive lift installation procedures. Never attempt to lift components without proper lifting tools such as forklift or cranes. Stay clear of any moving parts that can fall and cause injury. These instructions must be followed to ensure proper installation and operation of your lift. Failure to comply with these instructions can result in serious bodily harm and void product warranty. Manufacturer assumes no liability for loss or damage of any kind, expressed or implied resulting from improper installation or use of this product.



**PLEASE READ ENTIRE MANUAL
PRIOR TO INSTALLATION.**

DEFINITIONS OF HAZARD LEVELS

Identify the hazard levels used in this manual with the following definitions and signal words:



Watch for this symbol. It means: Immediate hazards that will result in severe personal injury or death.



Watch for this symbol. It means: Hazards or unsafe practices that could result in severe personal injury or death.



Watch for this symbol. It means: Hazards or unsafe practices that may result in minor personal injury, product, or property damage.

OWNER RESPONSIBILITY

To maintain the lift and user safety, the responsibility of the owner is to read and follow these instructions:

- ◆ Follow all installation and operation instructions.
- ◆ Make sure installation conforms to all applicable local, state, and federal codes, rules, and regulations; such as state and federal OSHA regulations and electrical codes.
- ◆ Carefully check the lift for correct initial function.
- ◆ Read and follow the safety instructions. Keep them readily available for machine operators.
- ◆ Make certain operators are properly trained, know how to safely and correctly operate the unit, and are properly supervised.
- ◆ Allow unit operation only with all parts in place and operating safely.
- ◆ Carefully inspect the unit on a regular basis and perform all maintenance as required.
- ◆ Service and maintain the unit only with authorized or approved replacement parts.
- ◆ Keep all instructions permanently with the unit and all decals on the unit clean and visible.

BEFORE YOU BEGIN

Receiving. The shipment should be thoroughly inspected as soon as it is received. The signed bill of lading is acknowledgment by the carrier of receipt in good condition of shipment covered by your invoice. If any of the goods called for on this bill of lading are shorted or damaged, do not accept them until the carrier makes a notation on the freight bill of the shorted or damaged goods. Do this for your own protection.

Notify the carrier at once if any hidden loss or damage is discovered after receipt and request the carrier to make an inspection. If the carrier will not do so, prepare a signed statement to the effect that you have notified the carrier (on a specific date) and that the carrier has failed to comply with your request.

It is difficult to collect for loss or damage after you have given the carrier a clear receipt. File your claim with the carrier promptly. Support your claim with copies of the bill of lading, freight bill, invoice, and photographs, if available. Our willingness to assist in helping you process your claim does not make BendPak responsible for collection of claims or replacement of lost or damaged materials.

TABLE OF CONTENTS

| | |
|--|----|
| Warranty / Serial Number | 2 |
| Definitions of Hazard Levels | 3 |
| Owner's Responsibility | 3 |
| Before You Begin. | 3 |
| Installer / Operator Agreement and Protective Equipment. | 5 |
| Safety / Warning Instructions | 6 |
| Tools Required. | 7 |
| Step 1 / Selecting Site | 7 |
| Step 2 / Floor Requirements | 7 |
| Concrete Specifications. | 7 |
| Main Assembly View / Parts Inventory | 8 |
| Floor Plan / Layout Dimensions | 9 |
| Specifications | 10 |
| Pit Installation | 12 |
| Step 3 / Locating the Lift | 12 |
| Step 4 / Locating the Console | 13 |
| Step 5 / Console/Hose Routing. | 13 |
| Step 6 / Flow Divider / Hose Installation | 14 |
| Step 7 / Power Unit Installation | 16 |
| Additional Power Unit Installation Information. | 17 |
| Step 8 / Routing Air Line Hoses. | 18 |
| Step 9 / Anchoring Lift Assemblies | 19 |
| Step 10 / Bleeding | 19 |
| Step 11 / Lift Start Up | 20 |
| Step 12 / Operation Instructions | 21 |
| Lift Operation Safety. | 21 |
| Maintenance Instructions. | 24 |
| Safe Lift Operation | 25 |
| Labels. | 27 |
| Troubleshooting. | 31 |
| Torque Specifications. | 34 |
| Installation Form. | 35 |
| Parts Listing. | 36 |
| Maintenance Log | 46 |

Installer / Operator: Please read and fully understand. By proceeding, you agree to the following:

- I have visually inspected the site where the lift is to be installed and verified the concrete to be in good condition and free of cracks or other defects. I understand that installing a lift on cracked or defective concrete could cause lift failure resulting in personal injury or death.
- I understand that a level floor is required for proper installation and level lifting.
- I understand that I am responsible if my floor is of questionable slope and that I will be responsible for all charges related to pouring a new level concrete slab if required.
- I understand that some Bendpak lifts are supplied with concrete fasteners meeting the criteria of the American National Standard "Automotive Lifts - Safety Requirements for Construction, Testing, and Validation" ANSI/ALI ALCTV-2011, and that I will be responsible for all charges related to any special regional structural and/or seismic anchoring requirements specified by any other agencies and/or codes such as the Uniform Building Code (UBC) and/or International Building Code (IBC).
- I assume full responsibility for the concrete floor and condition thereof, now or later, where the above equipment model(s) are to be installed. Failure to follow danger, warning, and caution instructions may lead to serious personal injury or death to operator or bystander or damage to property.
- I understand that BendPak lifts are designed to be installed in indoor locations only. Failure to follow installation instructions may lead to serious personal injury or death to operator or bystander or damage to property or lift.



Failure to follow danger, warning, and caution instructions may lead to serious personal injury or death to operator or bystander or damage to property.



Please read entire manual prior to installation. Do not operate this machine until you read and understand all the dangers, warnings, and cautions in this manual. For additional copies or further information, contact:

BendPak Inc. / Ranger Products

1645 Lemonwood Dr.
Santa Paula, CA. 93060
1-805-933-9970
www.bendpak.com

**INSTALLER / OPERATOR
PROTECTIVE EQUIPMENT**

Personal protective equipment helps makes installation and operation safer. However, it does not take the place of safe operating practices. Always wear durable work clothing during any installation and/or service activity. Shop aprons or shop coats may also be worn, however, loose fitting clothing should be avoided. Tight-fitting leather gloves are recommended to protect technician hands when handling parts. Sturdy leather work shoes with steel toes and oil resistant soles should be used by all service personnel to help prevent injury during typical installation and operation activities.



Eye protection is essential during installation and operation activities. Safety glasses with side shields, goggles, or face shields are acceptable. Everyday eyeglasses only have impact resistant lenses; they are not safety glasses. Back belts provide support during lifting activities and are also helpful in providing worker protection. Consideration should also be given to the use of hearing protection if service activity is performed in an enclosed area or if noise levels are high.



THIS SYMBOL POINTS OUT IMPORTANT SAFETY INSTRUCTIONS WHICH, IF NOT FOLLOWED, COULD ENDANGER THE PERSONAL SAFETY AND/OR PROPERTY OR YOURSELF AND OTHERS AND CAN CAUSE PERSONAL INJURY OR DEATH. READ AND FOLLOW ALL INSTRUCTIONS IN THIS MANUAL BEFORE ATTEMPTING TO OPERATE THIS MACHINE.

INTRODUCTION

1. Carefully remove the crating and packing materials.
CAUTION! Be careful when cutting steel banding material as items may become loose and fall causing personal harm or injury.
2. Check the voltage, phase, and proper amperage requirements for the motor shown on the motor plate.
Wiring should be performed by a certified electrician only.

IMPORTANT SAFETY INSTRUCTIONS

Read these safety instructions entirely

IMPORTANT NOTICE

Do not attempt to install this lift unless you have been trained on basic automotive lift installation procedures.
Never attempt to lift components without proper lifting tools such as forklift or cranes.
Stay clear of any moving parts that can fall and cause injury.

1. Read and understand all instructions and all safety warnings before operating lift.
2. Care must be taken as burns can occur from touching hot parts.
3. Do not operate equipment with a damaged cord or if the equipment has been dropped or damaged until it has been examined by qualified service personnel.
4. Do not let a cord hang over the edge of the table, bench, or counter or come in contact with hot manifolds or moving fan blades.
5. If an extension cord is necessary, a cord with a current rating equal to or more than that of the equipment should be used. Cords rated for less current than the equipment may overheat. Care should be taken to arrange the cord so that it will not be tripped over or pulled.
6. Always unplug equipment from the electrical outlet when not in use. Never use the cord to pull the plug from the outlet. Grasp plug and pull to disconnect.
7. Let equipment cool completely before putting away. Loop cord loosely around equipment when storing.
8. To reduce the risk of fire, do not operate equipment in the vicinity of open containers of flammable liquids (such as gasoline).
9. Adequate ventilation should be provided when working on operating internal combustion engines.
10. Keep hair, loose clothing, fingers, and all body parts away from moving parts. Keep feet clear of lift when lowering. Avoid pinch points.
11. **DANGER.** To reduce the risk of electric shock, do not use on wet surfaces or expose to rain. The power unit used on this lift contains high voltage. Disconnect power at the receptacle or at the circuit breaker switch before performing any electrical repairs. Secure plug so that it cannot be accidentally plugged in during service. Mark circuit breaker switch so that it cannot be accidentally switched on during service.
12. Use only as described in this manual. Use only manufacturer's recommended attachments.
13. **ALWAYS WEAR SAFETY GLASSES.** Everyday eyeglasses only have impact resistant lenses; they are not safety glasses.
14. Consider work environment. Keep work area clean. Cluttered work areas invite injuries. Keep areas well lit.
15. Guard against electric shock. This lift must be grounded while in use to protect operator from electric shock. Never connect the green power cord wire to a live terminal. This is for ground only.
16. Only trained employees should operate this lift. All non-trained personnel should be kept away from the work area. Never let non-trained personnel come in contact with or operate the lift.
17. **DO NOT** override self-closing lift controls.
18. Clear area if vehicle is in danger of falling.
19. **ALWAYS** make sure the safeties are engaged before attempting to work on or near a vehicle.
20. **WARNING! RISK OF EXPLOSION.** This equipment has internal arcing or sparking parts that should not be exposed to flammable vapors. This machine should not be located in a recessed area or below floor level.
21. **MAINTAIN WITH CARE.** Keep lift clean for better and safer performance. Read manual for proper lubrication and maintenance instructions. Keep control handles and/or buttons dry, clean and free from grease and oil.
22. Check for damaged parts. Check for alignment of moving parts, breakage of parts or any condition that may affect operation of lift. Do not use lift if any component is broken or damaged.
23. **NEVER** remove safety-related components from the lift. Do not use lift if safety-related components are missing or damaged.
24. **STAY ALERT.** Use common sense and watch what you are doing. Remember, **SAFETY FIRST.**



TOOLS REQUIRED

- ◆ Rotary Hammer Drill or Similar
- ◆ 3/4"; 3/8"; 1 1/4" Masonry Bits (for pit installation)
- ◆ Hammer
- ◆ 4 Foot Level
- ◆ Open-End Wrench Set: 1/2", 15/16" - 1-1/8"
- ◆ Socket And Ratchet Set: 1-1/8"
- ◆ Medium Crescent Wrench
- ◆ Crow Bar
- ◆ Chalk Line
- ◆ Medium Flat Screwdriver
- ◆ Tape Measure: 25 Foot Suggested

NOTE: An air supply (50 PSI Min. / 10 CFM Min.) will be required for the safety-lock mechanisms. See Step 11.

IMPORTANT NOTICE

These instructions must be followed to ensure proper installation and operation of your lift. Failure to comply with these instructions can result in serious bodily harm and void product warranty. Manufacturer assumes no liability for loss or damage of any kind, express or implied, resulting from improper installation or use of this product.

PLEASE READ ENTIRE MANUAL PRIOR TO INSTALLATION.

Step 1: Selecting a Site

Before installing your new lift, check the following.

1. **LIFT LOCATION:** Always use architectural plans when available. Check layout dimensions against floor plan requirements, making sure that adequate space is available.
2. **OVERHEAD OBSTRUCTIONS:** The area where the lift will be located should be free of overhead obstructions such as heaters, building supports, electrical lines, and so on.
3. **DEFECTIVE FLOOR:** Visually inspect the site where the lift is to be installed and check for cracked or defective concrete.



4. **OPERATING TEMPERATURE.** Operate lift only between temperatures of 41°F to 104°F.
5. Lift is designed for **INDOOR INSTALLATION ONLY.** Outdoor use permitted only if covered and dry. Always follow warnings on equipment labels.

Step 2: Floor Requirements



Your lift must be installed on a solid level concrete floor with no more than 3 degrees of slope. Failure to do so could cause personal injury or death.

A level floor is suggested for proper use and installation, and level lifting. If a floor is of questionable slope, consider a survey of the site and/or the possibility of pouring a new, *level* concrete slab.



- ◆ **DO NOT** install or use this lift on any asphalt surface or any surface other than concrete.
- ◆ **DO NOT** install or use this lift on expansion seams or on cracked or defective concrete.
- ◆ **DO NOT** install or use this lift on a second / elevated floor without first consulting the building architect.

Concrete Specifications

- MDS-6EXT: 4 inch minimum thickness
- MDS-6EXTF: 4 inch minimum thickness
- MDS-6LP: 4 inch minimum thickness
- MDS-6LPF: 4 inch minimum thickness



All models must be installed on 3000 PSI concrete only. The concrete must conform to the minimum requirements shown above. Additionally, new concrete must be adequately cured for a minimum of 28 days.

IMPORTANT NOTE:

BendPak lifts are supplied with installation instructions and concrete fasteners meeting the criteria as prescribed by the American National Standard "Automotive Lifts - Safety Requirements for Construction, Testing, and Validation" ANSI/ALI ALCTV-2011. Lift buyers are responsible for any special regional structural and/or seismic anchoring requirements specified by any other agencies and/or codes such as the Uniform Building Code (UBC) and/or International Building Code (IBC).

⚠ CAUTION

THIS LIFT SHOULD BE INSTALLED BY QUALIFIED LIFT INSTALLERS ONLY WHO ARE FAMILIAR WITH THIS PARTICULAR LIFT MODEL AND THE REQUIREMENTS THEREOF. THE FRAME ON THIS LIFT MUST NOT BE TWISTED, BENT, OR MISALIGNED BY NON-LEVEL FLOORS OR IMPROPER ANCHORING. MISALIGNMENT MAY CAUSE DAMAGE TO THE LIFT.

⚠ DANGER

WHEN REMOVING THE LIFT FROM SHIPPING PALLET / ANGLES, PAY CLOSE ATTENTION AS LIFT ASSEMBLIES CAN SLIDE AND CAN CAUSE INJURY. PRIOR TO REMOVING ANY STRAPPING OR SHIPPING BOLTS, MAKE SURE THE LIFT IS HELD SECURELY BY A FORK LIFT OR SOME OTHER HEAVY LIFTING DEVICE.

PARTS INVENTORY

Be sure to take a complete inventory of parts prior to beginning installation.

MDS-6EXT / MDS-6LP

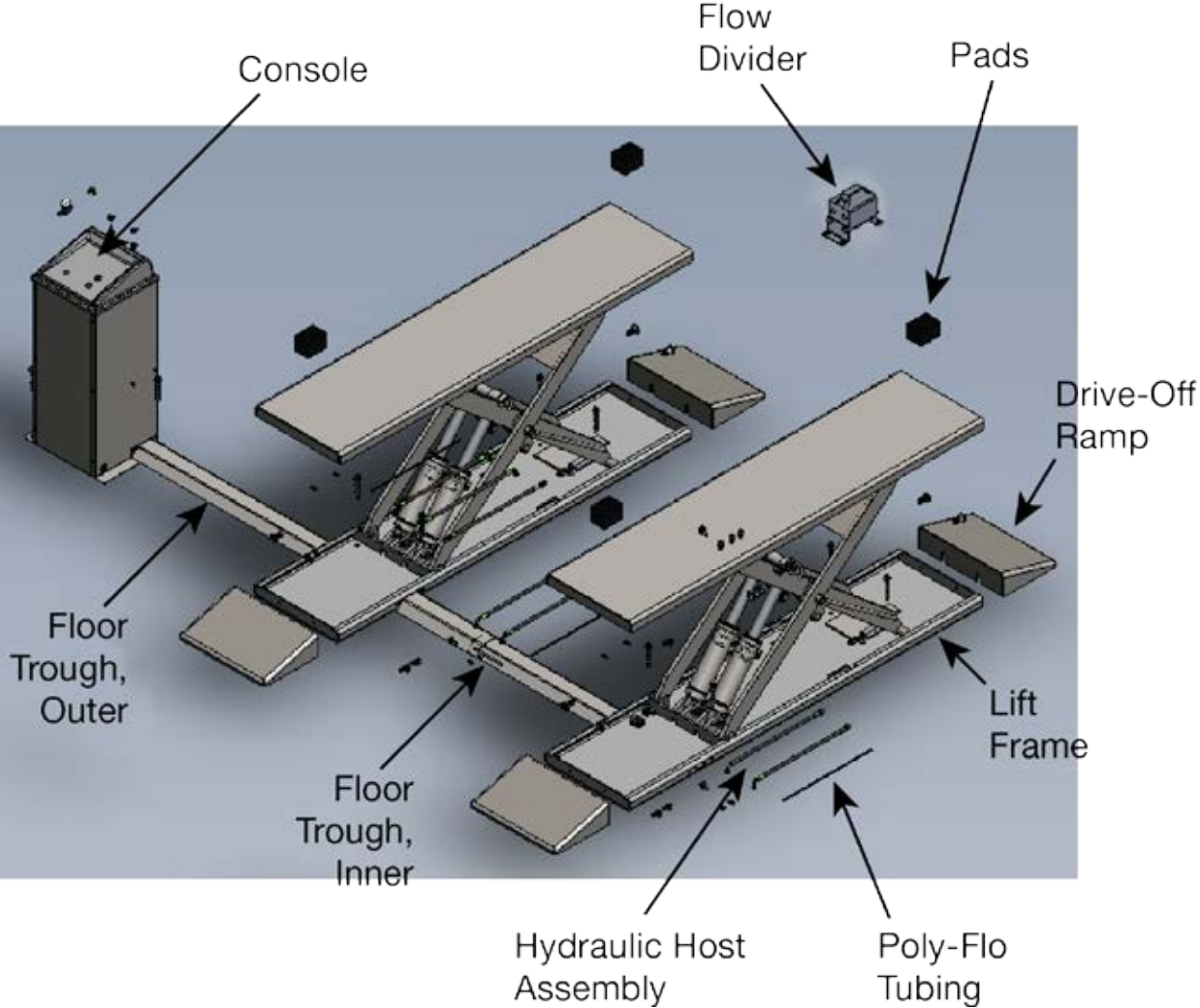

MDS-6EXTF / MDS-6LPF

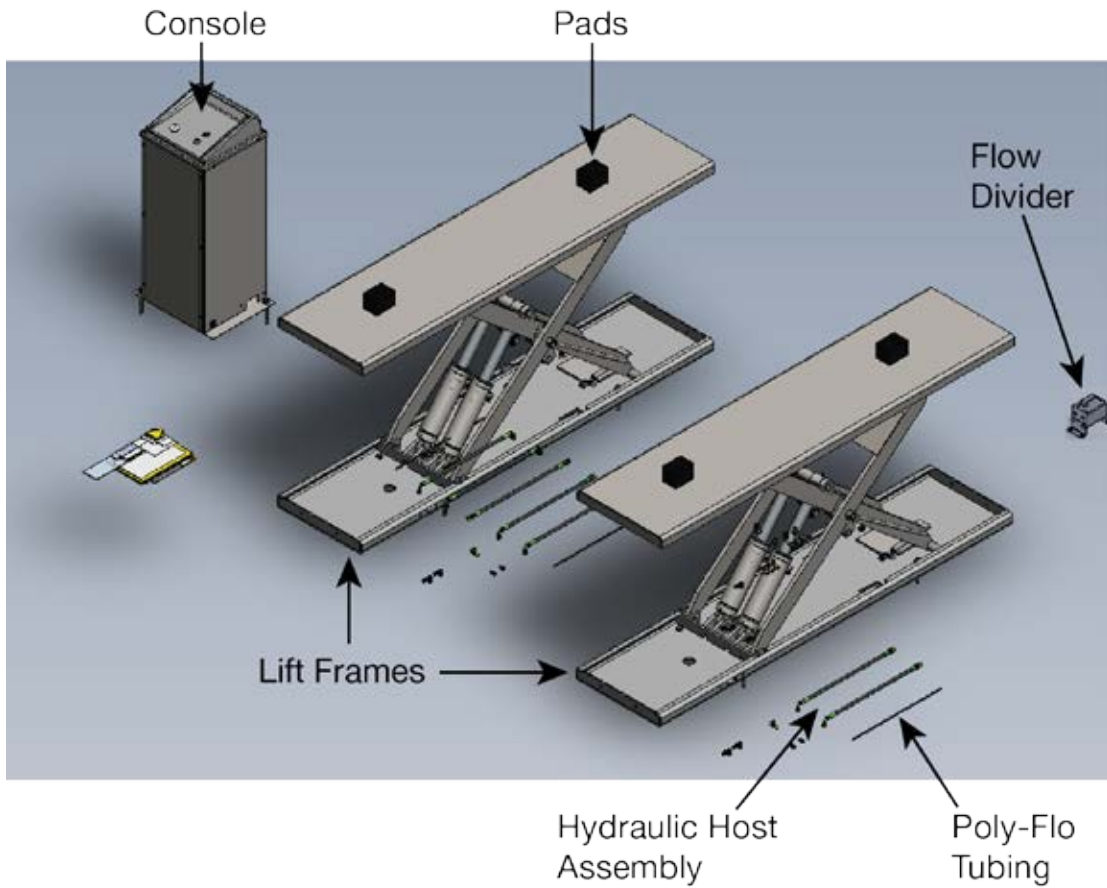

FLOOR PLAN/LAYOUT DIMENSIONS

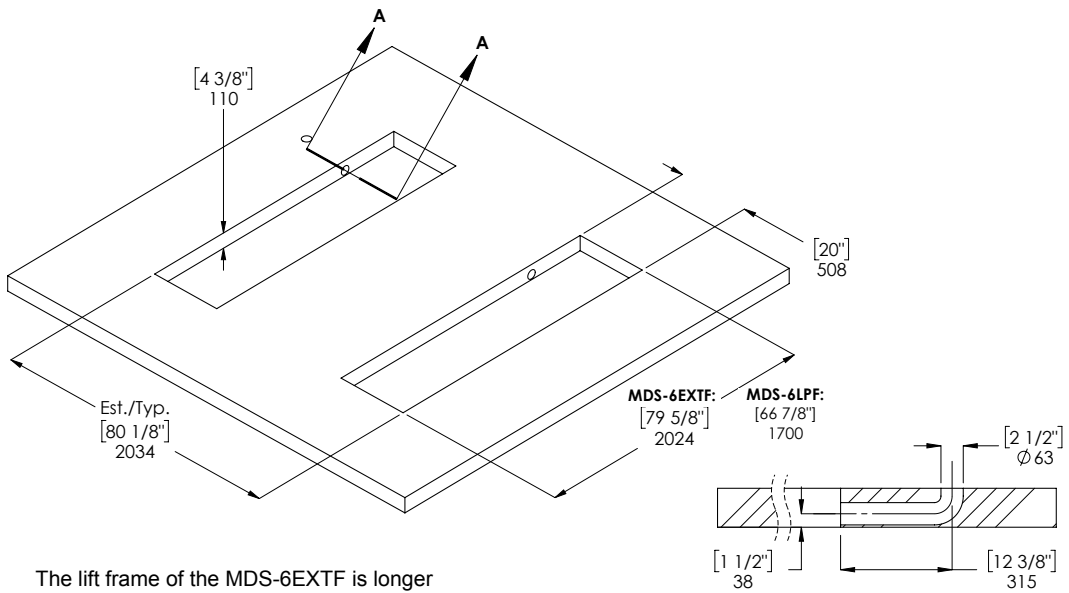

The lift frame of the MDS-6EXTF is longer than the lift frame of the MDS-6LPF, so the concrete cutout must also be longer:

- **MDS-6EXTF:** 2,024 mm (79 5/8 in)
- **MDS-6LPF:** 1,700 mm (66 7/8 in)

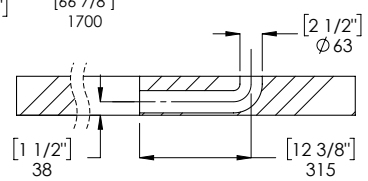

| | | | | |
|---|----|------------|------|---|
| DO NOT SCALE DRAWING | | NAME | DATE | BP BendPak. 1645 LEMONWOOD DR. SANTA PAULA, CA 93060 |
| DRAWN | IM | 02/02/2017 | | |
| CHECKED | -- | -- | -- | TITLE: MDS-6EXTF FLUSH MOUNT CONCRETE PRE-POUR LAYOUT |
| THIRD ANGLE PROJECTION | | | | SCALE: 1:25 |
| <small>REFERENCED AND CONTAINED THE INFORMATION CONTAINED IN THIS DRAWING IS THE SOLE PROPERTY OF BENDPAK INC. 2017. REPRODUCTION IN PART OR AS A WHOLE WITHOUT THE WRITTEN PERMISSION OF BENDPAK INC. IS PROHIBITED.</small> | | | | SHEET 1 OF 1 REV A |

FLOOR PLAN/LAYOUT DIMENSIONS

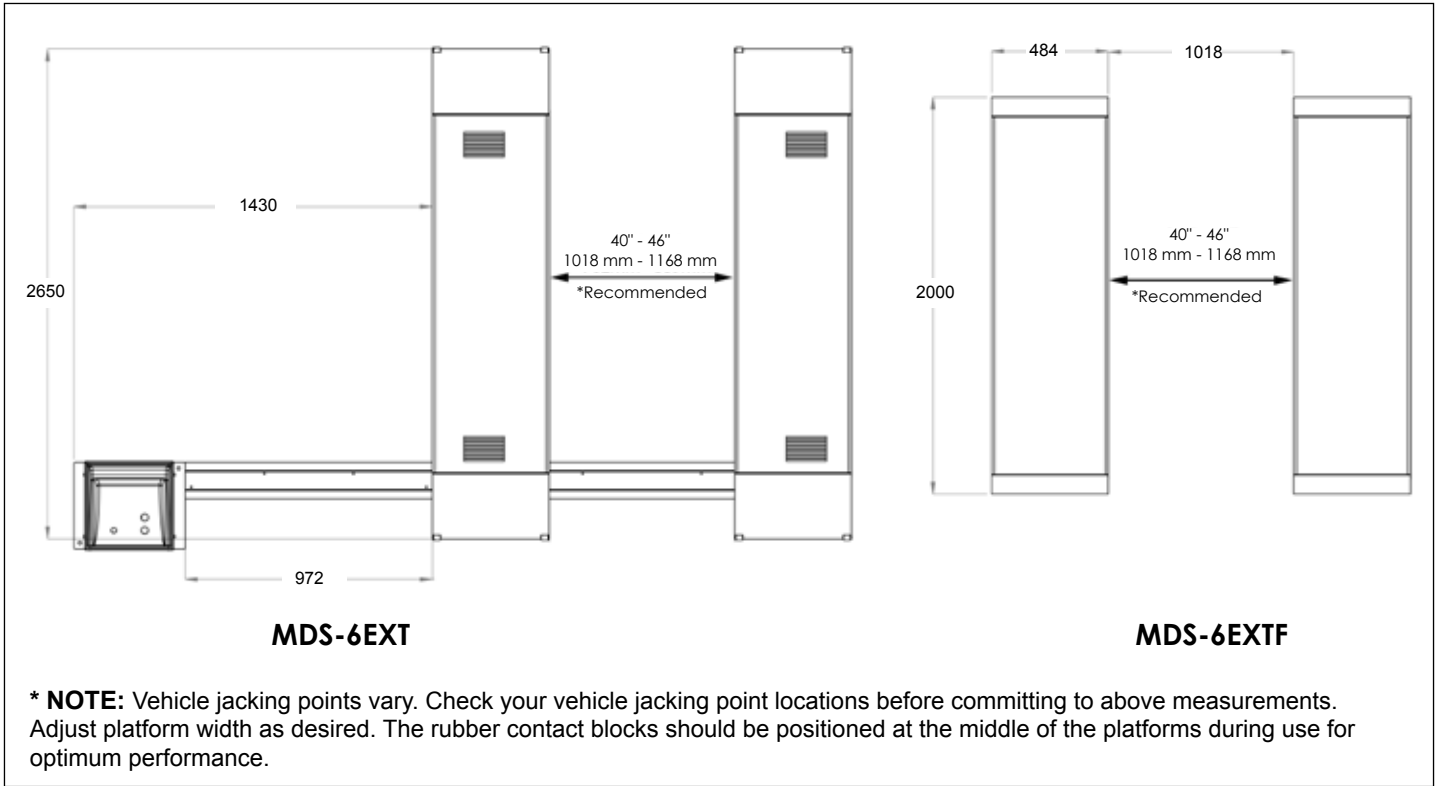

| MODEL | MDS-6EXT | MDS-6EXTF |
|--|---|--|
| Style | Mid-Rise Scissor Car Lift / Surface Mount | Mid-Rise Scissor Car Lift / Flush Mount |
| Lifting Capacity: | 6,000 lbs / 2,722 kg | 6,000 lbs / 2,722 kg |
| Lifting Height (Less Lift Blocks) | 36.6" / 930 mm | 36.6" / 930 mm (-4.3/8" for sub-floor) |
| Lifting Height (With Lift Blocks) | 38.1" / 968.5 mm | 38.1" / 968.5 mm (-4.3/8" for sub-floor) |
| Lift Platform Dimensions | 19" x 78.7" / 484 mm x 2,000 mm | 19" x 78.7" / 484 mm x 2,000 mm |
| Width Between Platforms | 40" to 46" / 1,018 mm to 1,168 mm | 40" to 46" / 1018 mm to 1,168 mm |
| Overall Width | 19" / 484 mm | 19" / 484 mm |
| Overall Length | 104.3" / 2,650 mm | 78.7" / 2,000 mm |
| Lowered Height | 4.3" / 110 mm | 4.3" / 110 mm / (-4.3/8" for sub-floor) |
| Lifting Time | 35 seconds | 35 seconds |
| Motor * | 220 VAC / 60 HZ / 1 Phase | 220 VAC / 60 HZ / 1 Phase |

* Special voltage available on request.

Design, materials, and specifications shown here are subject to change without notice.

Note: An air supply (minimum 50 psi / 10 CFM) is required for the safety-lock mechanisms to disengage. It is **solely your responsibility** to install and maintain the air supply.

FLOOR PLAN/LAYOUT DIMENSIONS

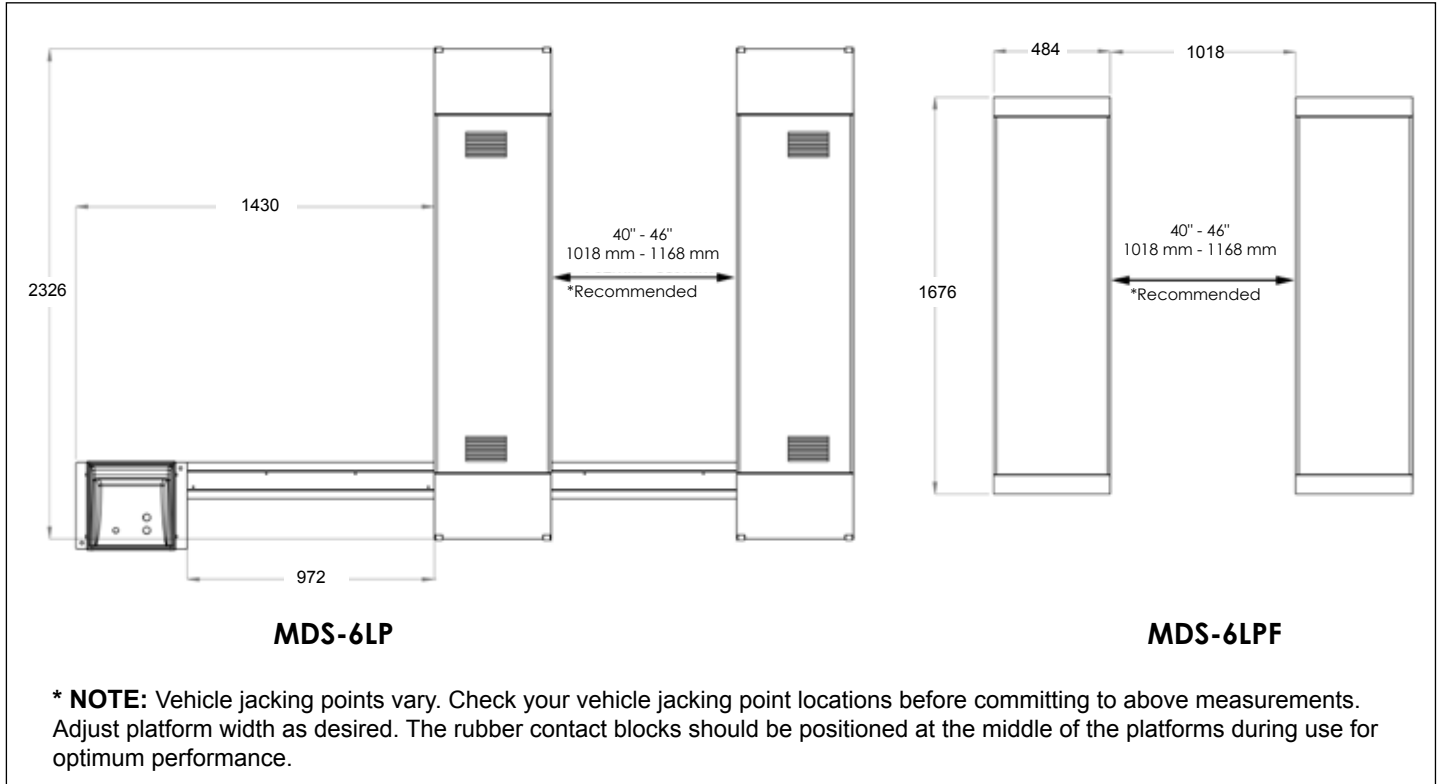

| MODEL | MDS-6LP | MDS-6LPF |
|---|---|--|
| Style | Mid-Rise Scissor Car Lift / Surface Mount | Mid-Rise Scissor Car Lift / Flush Mount |
| Lifting Capacity: | 6,000 lbs / 2,722 kg | 6,000 lbs / 2,722 kg |
| Lifting Height (Less Lift Blocks) | 42.5" / 1,087 mm | 42.5" / 1,087 mm (-4.3/8" for sub-floor) |
| Lifting Height (With Lift Blocks) | 44.5" / 1,125 mm | 44.5" / 1,125 mm (-4.3/8" for sub-floor) |
| Lift Platform Dimensions | 19" x 66" / 484 mm x 1676 mm | 19" x 66" / 484 mm x 1676 mm |
| Width Between Platforms | 40" to 46" / 1018 mm to 1168 mm | 40" to 46" / 1018 mm to 1168 mm |
| Over Width | 19" / 484 mm | 19" / 484 mm |
| Overall Length | 91.5" / 2,326 mm | 66" / 1,676 mm |
| Lowered Height | 4.3" / 110 mm | 4.3" / 110 mm / (-4.3/8" for sub-floor) |
| Lifting Time | 35 seconds | 35 seconds |
| Motor * | 220 VAC / 60 HZ / 1 Phase | 220 VAC / 60 HZ / 1 Phase |
| * Special voltage available on request. Design, materials, and specifications shown here are subject to change without notice. | | |
| Note: An air supply (minimum 50 psi / 10 CFM) is required for the safety-lock mechanisms to disengage. It is solely your responsibility to install and maintain the air supply. | | |

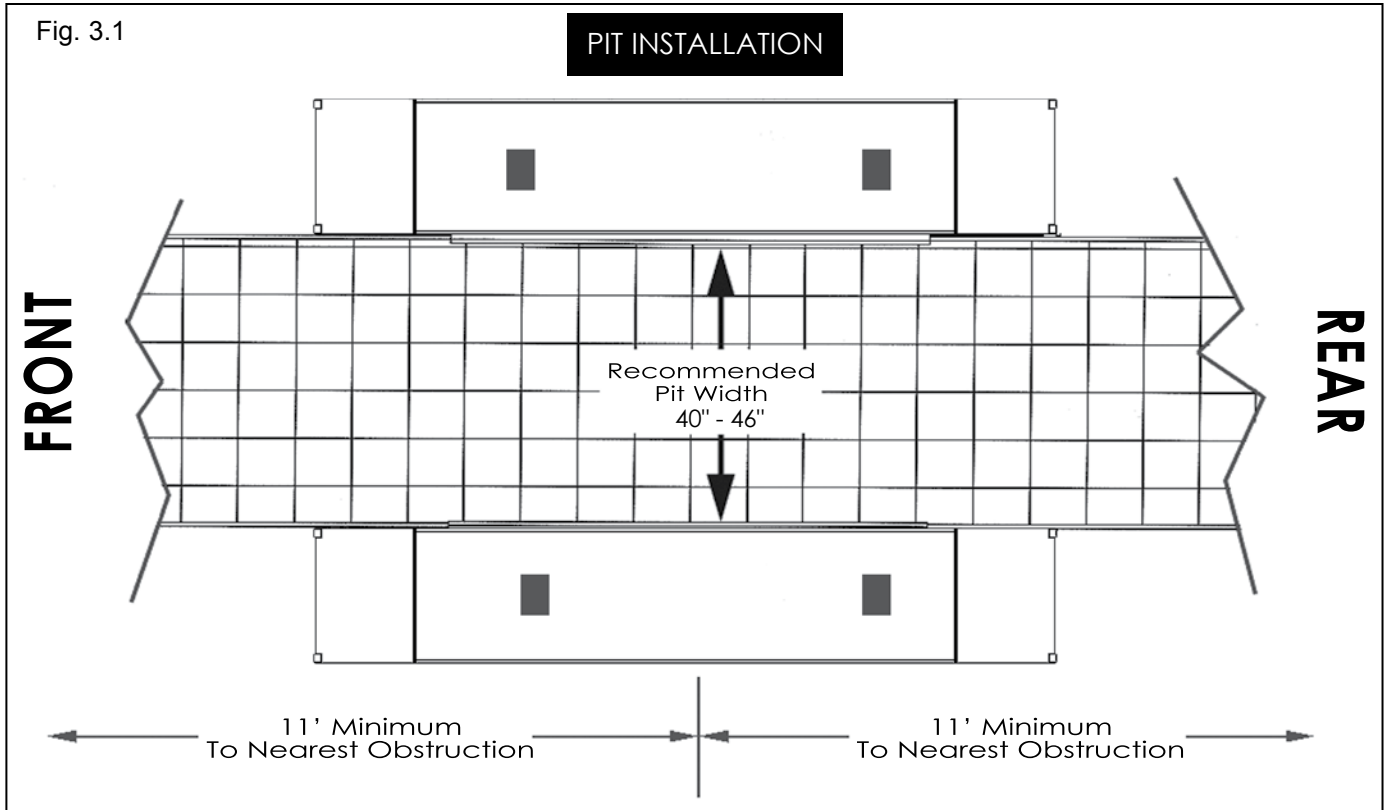

Step 3: Locating the Lift

1. Before selecting an installation site, check for proper clearance and/or obstructions. (See Fig 3.1)
2. Always consult the building engineer before installing this lift to make sure the floor is capable of sustaining the load.
3. After selecting a site, place each unit adjacent to the power unit console. Make sure frames and cylinder ports are facing the same position. (See Fig. 3.2)
4. An air supply (minimum: 50 psi / 10 CFM) is required for the safety-lock mechanisms to disengage.
5. The hookup work must be carried out by a qualified electrician.
6. Make sure the connection of the phases is correct. Improper electrical hook-up can damage the motor and is not covered under the warranty.

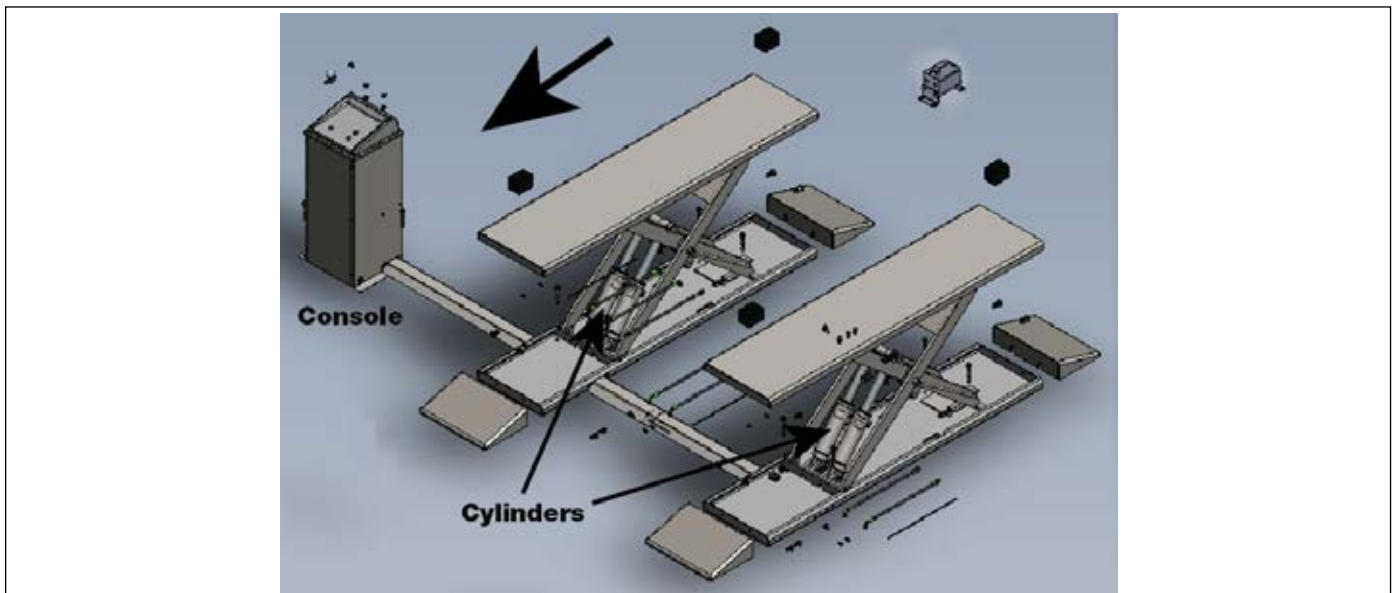
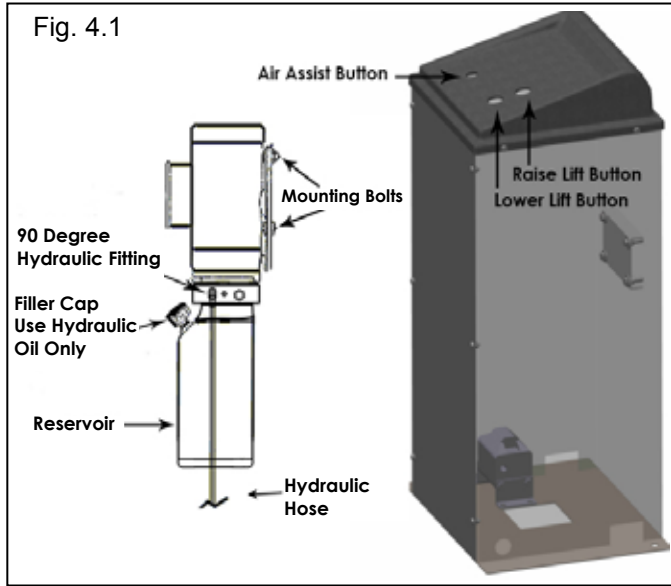

Fig. 3.2

Step 4: Locating the Console

1. Select a site for the Power Unit Console that permits operators to have a full, unobstructed view of the lift.
2. It is recommended that the Hydraulic Hose and Air Safety Line be routed through the floor at the base of the Power Unit, so check for routing clearances.



RISK OF EXPLOSION. DO NOT INSTALL THE POWER UNIT INSIDE OR NEAR A PAINT BOOTH. THIS EQUIPMENT HAS INTERNAL ARCING OR SPARKING PARTS THAT SHOULD NOT BE EXPOSED TO FLAMMABLE VAPORS.



CHECK WITH BUILDING PLANS PRIOR TO DRILLING ANY HOLES IN FLOOR.

3. Using the Power Unit Stand as a template, mark the locations of the two anchor bolt holes.
4. Drill two holes 3/8" wide by 4" deep in the concrete floor.
5. Remove all dust from the holes.

6. Secure the Power Unit Console to the floor using two 3/8" screws, supplied.
7. Attach the Power Unit to the Motor Bracket using four 5/16" hex bolts and nyloc nuts, supplied. NOTE: Motor must be at least 18" above floor.
8. Install the Air Safety Valve "Z" bracket on the upper left mounting hole of the Power Unit Stand.

Step 5: Console/Hose Routing

1. Remove the front panel cover on the Power Console.
2. Route the Hydraulic Hoses and the Air Line through the holes at the back of the Power Console. (See Fig. 5.1)

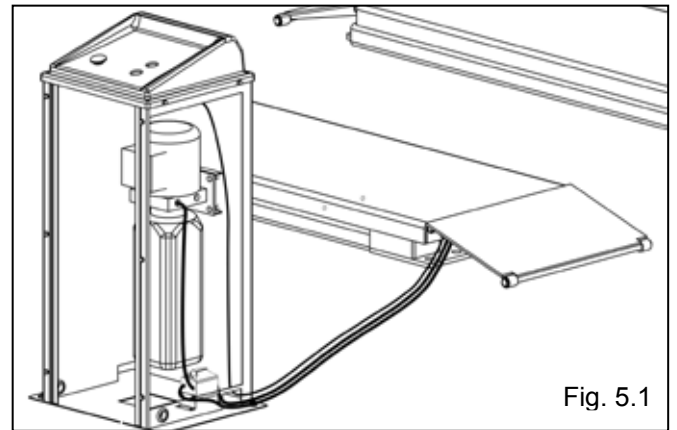

3. Connect the Power Unit Hydraulic Hose (shortest) to the Power Unit Fitting, as shown in the image below. It is not necessary to use Teflon tape on JIC fittings.

Do not overtighten. (See Fig. 5.2)

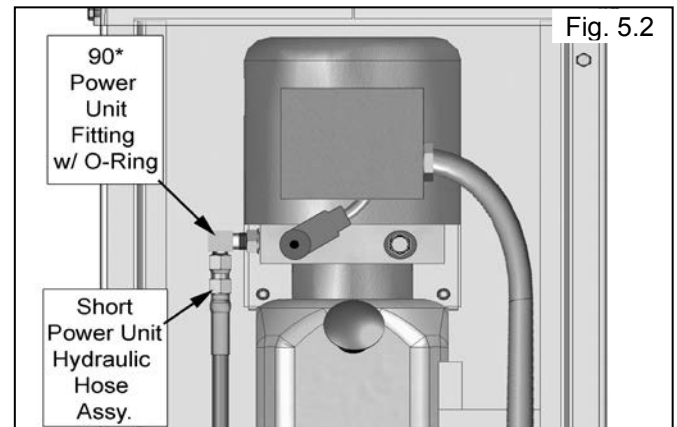

4. Install the two 90° fittings and one straight fitting in the Flow Divider, configured as shown. (See Fig. 5.3).

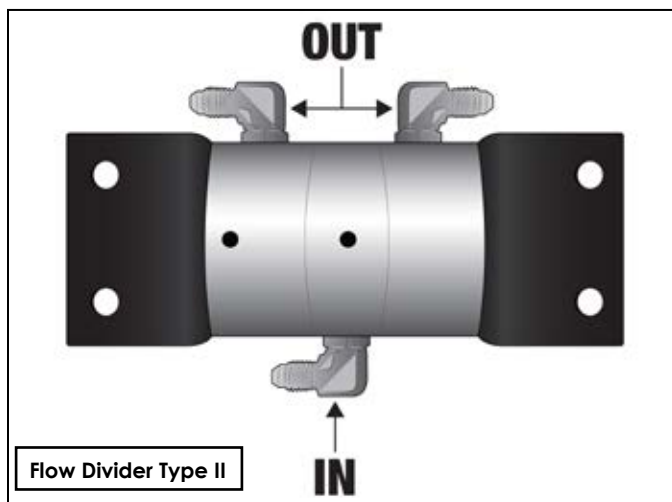
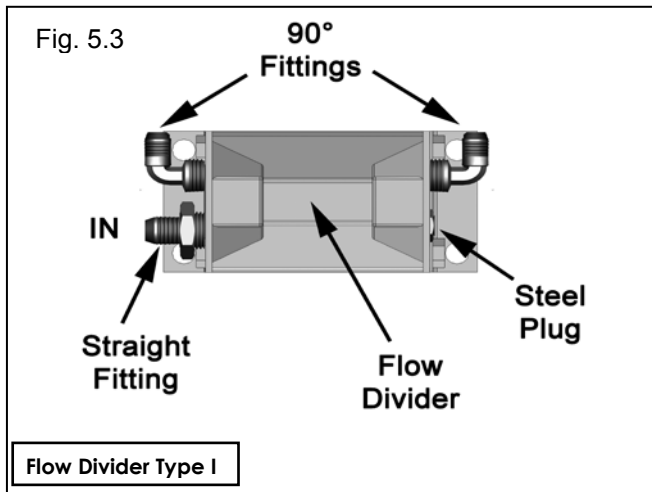

5. Install the Flow divider in the bottom of the Power Console.
6. Connect the Power Unit Hose to the Straight Fitting on the Flow Divider and connect both the Powerside and Offside Hydraulic Hoses to the 90° Fittings on the Flow divider as shown. (See Fig. 5.4)

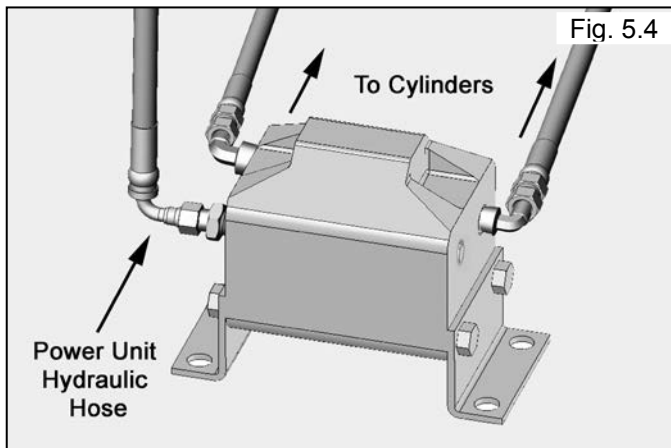

7. Route the 1/4" Poly-Flow Air Tubing through the hole at the back of the Power Console and connect to the Push Button Air Safety Switch. (See Fig. 5.5)

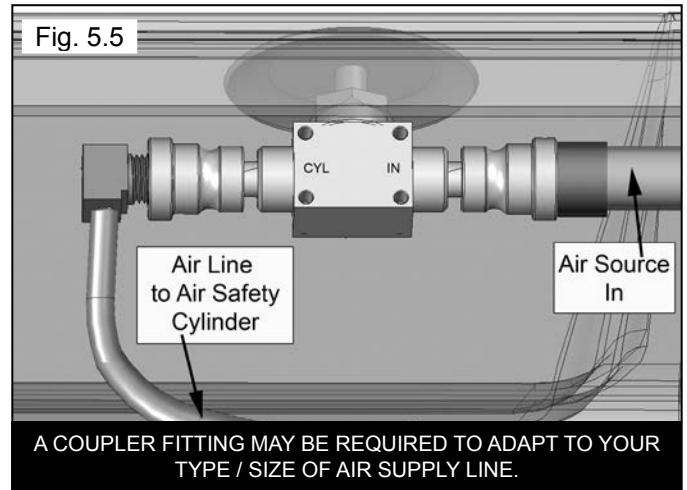

Step 6: Flow Divider/Hose Installation

1. For pit installation, secure the Hydraulic Flow Divider to a permanent wall or fixture (usually below ground level) in an area that will allow the Power Hoses (the two hoses that are installed at the lift Cylinders) to be equal length.

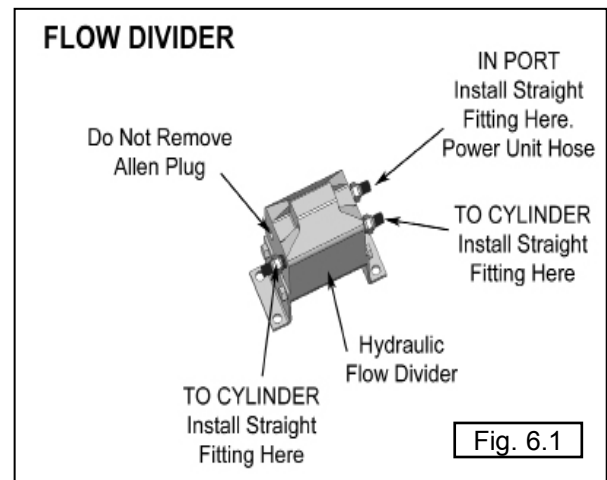

POWER HOSES MORE THAN 12" DIFFERENCE IN LENGTH MAY RESULT IN UNEQUAL LIFTING OF THE SYSTEM.

It may be necessary to add hose extensions to accommodate installation. If so, keep the power hoses as close to equal length as possible to provide equal pressure and lifting.

2. Install the 90 Degree Hydraulic Fitting in the pressure port of the Power Unit. The pressure port is covered with a plastic plug. Use Teflon tape on pipe fittings **only**.
3. After the fitting is installed correctly, connect the 1/4 inch Hydraulic Hose; **do not over-tighten**.

ROUTING HYDRAULIC HOSES

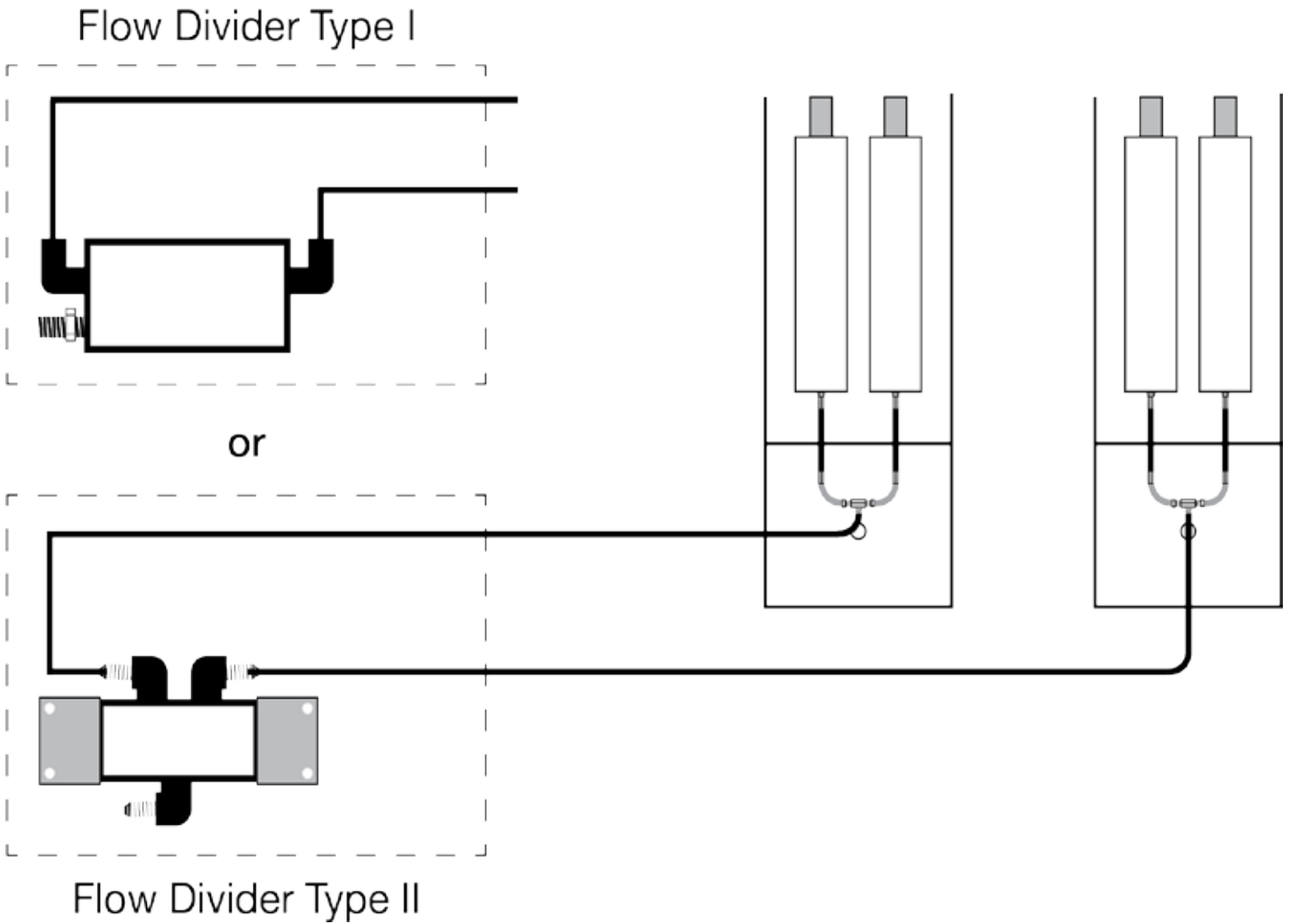

⚠ CAUTION

CHECK WITH BUILDING PLANS PRIOR TO DRILLING ANY HOLES IN FLOOR.

For below ground level hose installations, a 1 1/4" hole should be drilled through the floor at the base of the Power Unit so the hose can be routed below ground. (See Fig 6.2)

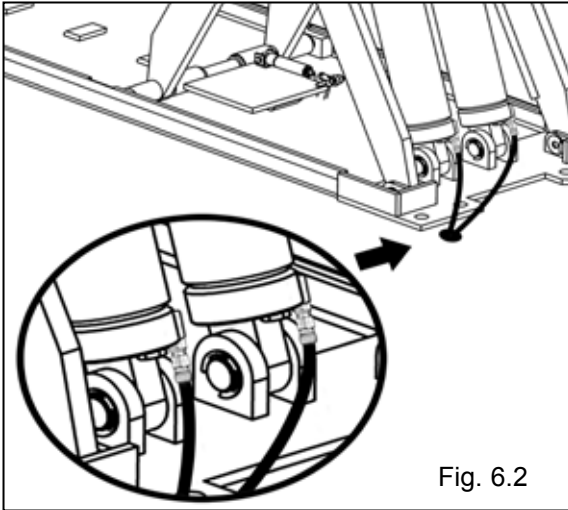

4. Connect the other end of the Power Unit Hose to the fitting marked "IN" on the Flow Divider. (See Fig 6.1)
5. Connect the two remaining equal length Hoses to the Flow Divider. (See Fig 6.1)

You can use 3/8" I.D. hydraulic tubing / hose rather than the hose provided as long as it is rated for 3,000 PSI operating pressure with 12,000 PSI burst pressure rating.

Step 7: Power Unit Installation

⚠ WARNING

RISK OF EXPLOSION. DO NOT INSTALL THE POWER UNIT INSIDE OR NEAR A PAINT BOOTH. THIS EQUIPMENT HAS INTERNAL ARCING OR SPARKING PARTS WHICH SHOULD NOT BE EXPOSED TO FLAMMABLE VAPORS.

MOTOR SHOULD NOT BE LOCATED IN A RECESSED AREA OR BELOW FLOOR LEVEL. NEVER EXPOSE MOTOR TO RAIN OR OTHER DAMP ENVIRONMENTS. DAMAGE TO MOTOR CAUSED BY WATER IS NOT COVERED UNDER WARRANTY.

1. Have a certified electrician run power to the motor. Refer to the data plate found on the motor for proper power supply and wire size.

Note: Refer to the wiring diagram on page 17 (Fig. 7.2) for detailed wiring information. Electricians must reference the UL 201 standard, clause 12.1, for information about wire types that are allowed for use.

⚠ CAUTION

ALWAYS USE A SEPARATE CIRCUIT FOR EACH LIFT. BE SURE TO USE PROPER CIRCUIT BREAKERS OR TIME DELAY FUSES TO PROTECT CIRCUIT.

2. **Fill the reservoir with 10 WT. HYDRAULIC OIL OR DEXRON TYPE III ATF**, approximately 6 quarts. Make sure the funnel used to fill the tank and power unit is clean.

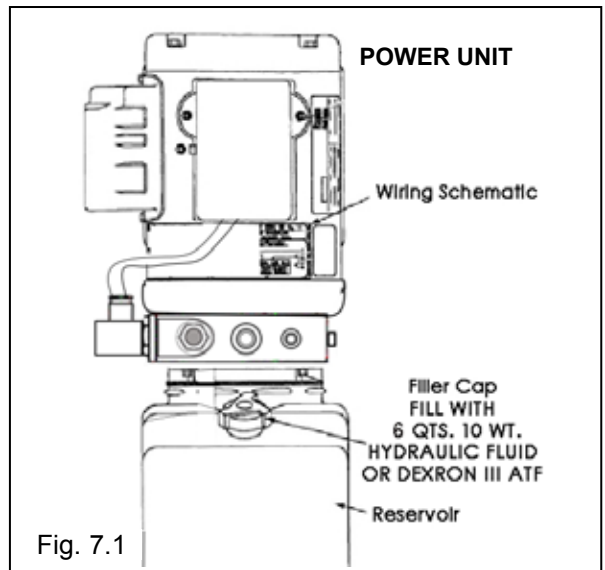

3. The standard power unit for your lift is 220 VAC / 60 HZ, single phase.

Important: All wiring must be performed by a certified electrician only. Refer to the labels on the console and on the power unit for additional information.

Additional Power Unit Installation Information

- **All wiring must be performed by a certified electrician only.**
- **It is the responsibility of the electrician to ensure that all wiring complies with both NEC recommendations and all additional electrical codes.**
- Electricians must reference the UL 201 standard, clause 12.1, for information about wire types that are allowed for use.
- Do not perform any maintenance or installation of any components without first making sure that electrical power has been disconnected at the source or panel and cannot be re-energized until all maintenance and/or installation procedures are complete.
- Do not run the power unit without oil; **damage to the power unit pump can occur.**
- The power unit must be kept dry; damage to the power unit caused by water or other liquids such as detergents, acid, and so on, is **not** covered by your warranty.
- Operate power unit only between temperatures of 41°F to 104°F (5°C to 40°C).
- Improper electrical installation can damage the power unit motor; resulting damage is not covered by your warranty.
- The motor cannot run on 50 HZ without a physical change to the motor.
- Use a separate circuit breaker for each power unit. protect each circuit with a time delay fuse or circuit breaker:
 - For 208 - 230 Volt, single phase, use a 25 amp fuse.
 - For 208 - 230 Volt, three phase, use a 20 amp fuse.
 - For 380 - 440 Volt, three phase, use a 15 amp fuse.

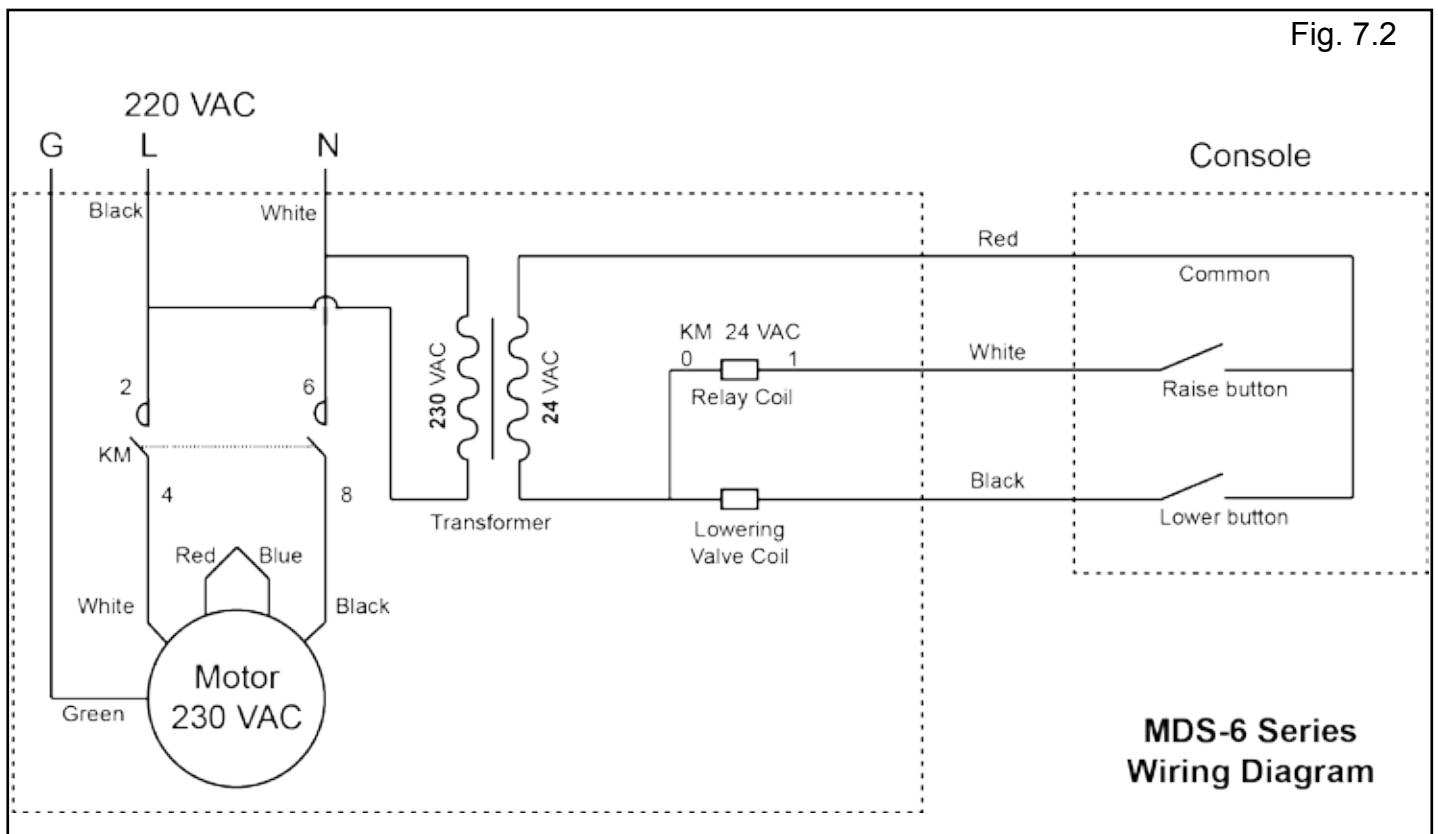

Step 8: Routing Air Lines Hoses

1. Connect the Air Safety Cylinders to the Air Safety Valve using the Tee Fitting and the Air Line. Route the Air Line as shown in Fig. 8.1, making sure to position the push button air valve with the INLET facing towards the AIR SOURCE and the OUTLET facing towards the lift.
2. A filter/regulator/lubricator must be installed on the air supply at the lift. Failure to do so voids the warranty.
3. Cut the provided 1/4" air line tubing with a sharp blade to lengths as required. Tubing must be cut square with no burrs.

NOTE: Improper assembly can result in safety lock failure. Connect the Air Supply Hose to push the Air Release Valve inside the Power Unit Console. On the opposite side of the Air Release Valve, connect 1/4" Poly-Flo Air Tubing. Route the 1/4" Poly-Flo Air Tubing through the hole on the Powerside of the Lift Frame and connect it to the Tee Fitting. Connect the Air Line to each Air Safety Cylinder.

NOTE: An air supply (minimum 50 psi / 10 CFM) is **required** for the safety-lock mechanisms to disengage. It is your responsibility to provide, install, and maintain the air supply. **Air pressure should be regulated to 125 psi maximum.**

ROUTING AIR LINE HOSES

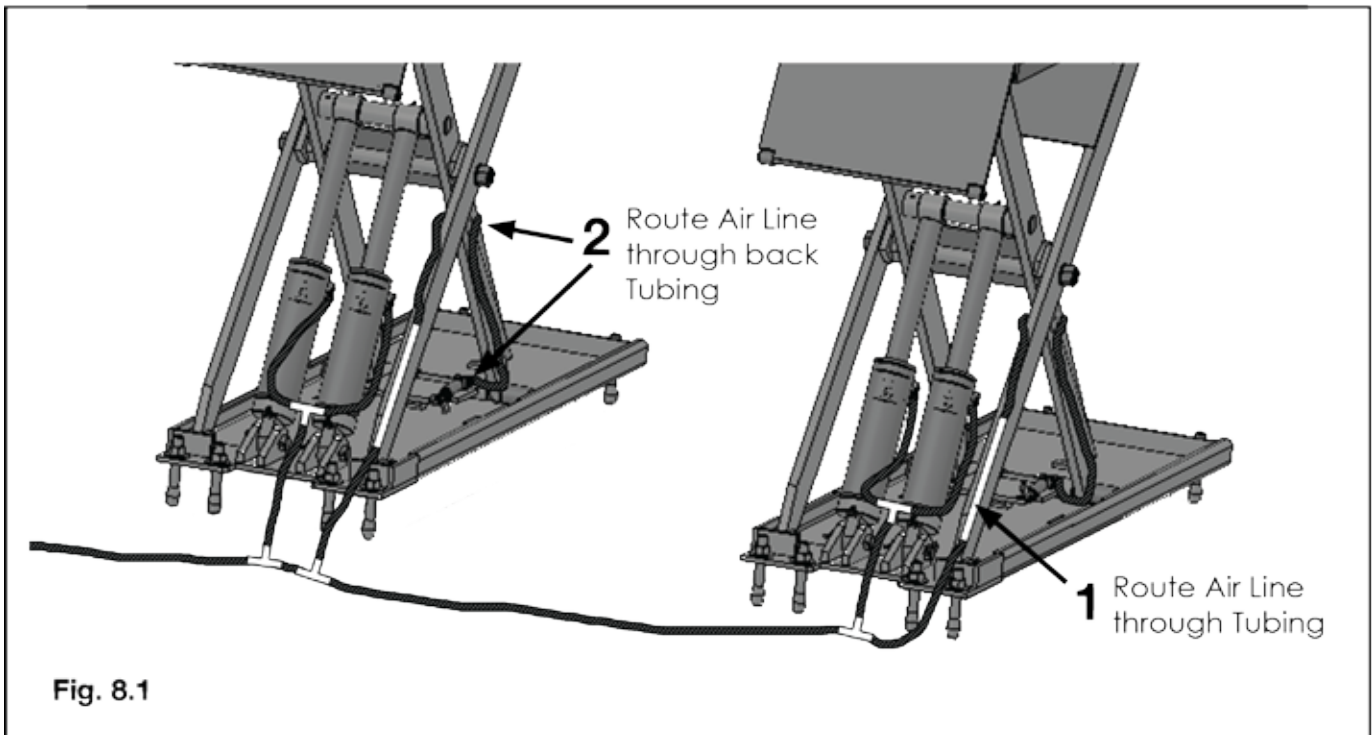

Step 9: Anchoring Lift Assemblies

NOTE:

BENDPAK LIFTS ARE SUPPLIED WITH INSTALLATION INSTRUCTIONS AND CONCRETE FASTENERS MEETING THE CRITERIA AS PRESCRIBED BY THE AMERICAN NATIONAL STANDARD "AUTOMOTIVE LIFTS - SAFETY REQUIREMENTS FOR CONSTRUCTION, TESTING, AND VALIDATION" ANSI/ALI ALCTV-2011. LIFT BUYERS ARE RESPONSIBLE FOR ANY SPECIAL REGIONAL STRUCTURAL AND/OR SEISMIC ANCHORING REQUIREMENTS SPECIFIED BY ANY OTHER AGENCIES AND/OR CODES SUCH AS THE UNIFORM BUILDING CODE (UBC) AND/OR INTERNATIONAL BUILDING CODE (IBC).



NOTE: For "pre-fab" or steel grate floors, check with the building engineer for mounting suggestions. It may be necessary to install all-thread rods through the floor and secure above and below.

1. Before anchoring the lift to the floor, make sure the location is satisfactory (refer to Steps 1 through 4).
2. Locate the four bolt holes in the lift base frame. (See Fig 9.1)

NOTE: The lift must be elevated *prior* to drilling holes.

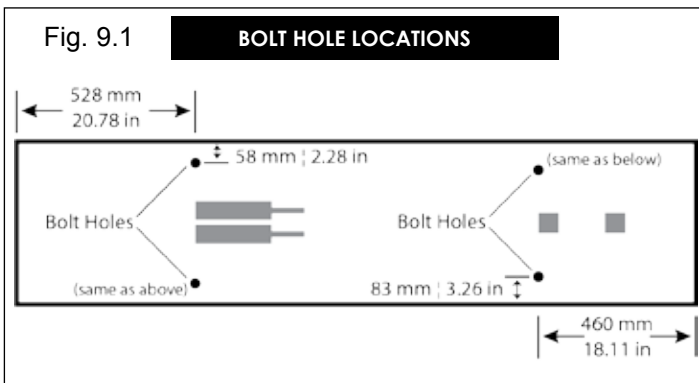

3. Using a 3/4" concrete bit, drill 4 holes on each pad 5" deep using the holes in the frame as a guide. (See Fig 9.2)

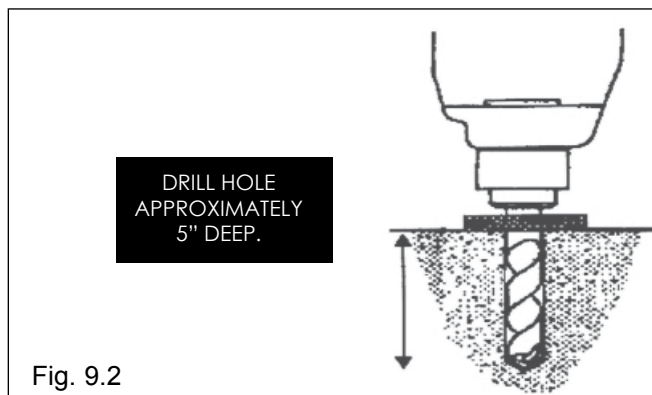

4. Using compressed air or vacuum, remove all excess dust from the holes, then install the anchor bolts. (See Fig 9.3)

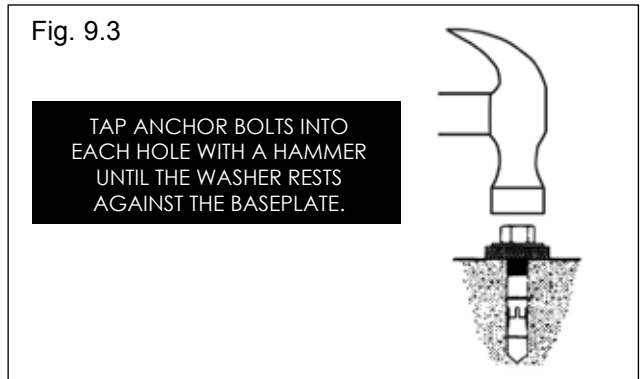

5. Tighten the anchor bolts 2 or 3 turns using an open end wrench or manual ratchet only. **DO NOT** use an impact wrench to tighten concrete anchors. (See Fig 9.4)

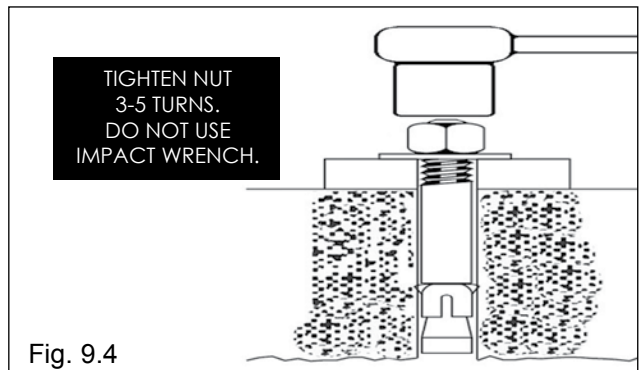

Step 10: Bleeding

NOTE: The lift must be fully lowered before changing or adding fluid.

1. Raise and lower lift 6 times. The cylinders are self-bleeding. After bleeding the system, the fluid level in power unit reservoir may be down. Add more fluid if necessary to raise lift to full height. It is only necessary to add fluid to raise lift to full height.
2. It may be necessary to disconnect hoses at the cylinders and run the Power Unit to completely bleed the system of air. Consult a trained professional if you are not familiar with this type of bleeding procedure.
3. To perform a pressure test, run the lift to full rise and run the motor for approximately 3 seconds after the lift stops. This will place pressure on the hydraulic system. Stop and check all fittings and hose connections. Tighten or reseal if required.
4. Raise the lift **halfway only**, then lower it completely at least 12 times. During initial testing the lift will descend slowly—this is normal. It helps to add a payload, no greater than 500 pounds, to help speed up the decent during this process.
5. Check all hoses for leaks. Tighten if necessary.

Step 11: Lift Start Up

1. Make sure the Power Unit Reservoir is full with 6 quarts / 1.5 gallons of 10 WT hydraulic oil or Dexron-III automatic transmission fluid. Other approved options are Dexron VI, Mercon V, Mercon LV, or comparable.
2. Make sure all grease fittings are installed and lubricated. There are eight: pin receivers on the hydraulic cylinders' rods, base cylinder clevises, main scissor pins, base scissor clevises of inner and outer scissor arms clevises. Use 90 weight gear oil and a grease gun with appropriate tip (Lube-Link™, for example).
3. Test the Power Unit by pressing the push-button switch. If the motor sounds like it is operating properly, raise the lift and check all hose connections for leaks. If the motor gets hot or sounds peculiar, stop and check all electrical connections.
3. Raise lift until the cylinder bottoms out and the lift stops.



VISUALLY CONFIRM THAT ALL PRIMARY SAFETY LOCKS ARE ENGAGED BEFORE ENTERING WORK AREA. SUSPENSION COMPONENTS USED ON THIS LIFT ARE INTENDED TO RAISE AND LOWER LIFT ONLY AND ARE NOT MEANT TO BE LOAD HOLDING DEVICES. REMAIN CLEAR OF ELEVATED LIFT UNLESS VISUAL CONFIRMATION IS MADE THAT ALL PRIMARY SAFETY LOCKS ARE FULLY ENGAGED AND THE LIFT IS LOWERED ONTO THE SAFETY LOCKS.

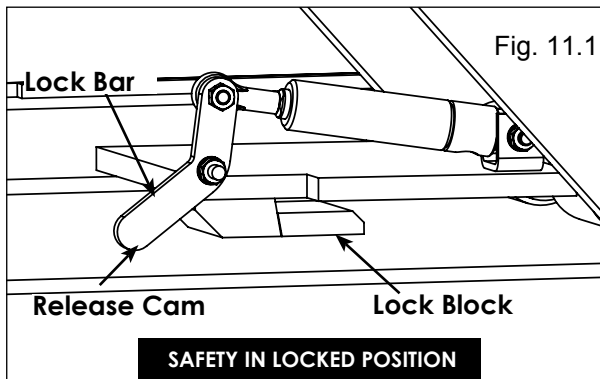

ALWAYS MAKE SURE THE SAFETY IS IN LOCKED POSITION BEFORE ANY ATTEMPT IS MADE TO WORK ON OR NEAR THE VEHICLE.

4. Check all **main safety locks** to make sure they move freely and fall back to the lock position when released. Lubricate all **safety pivot points** with WD-40 or equal.



KEEP HANDS AND FEET CLEAR OF THE LIFT. REMOVE HANDS AND FEET FROM ANY MOVING PARTS. KEEP FEET CLEAR OF LIFT WHEN LOWERING. AVOID PINCH POINTS. READ THE ENTIRE CONTENTS OF THIS MANUAL PRIOR TO INSTALLATION AND OPERATION. FAILURE TO FOLLOW DIRECTIONS AS INSTRUCTED MAY CAUSE INJURY OR DEATH.

5. Run the lift up and down a few times to make sure the locks are engaging uniformly and the safety release mechanisms are functioning.

Post-Installation Checklist

- Columns are properly shimmed and stable
- Anchor bolts tightened
- Grease fittings installed and greased
- Pivot/sheave pins properly attached
- Electric power supply confirmed
- Safety locks functioning properly
- Hydraulic leaks checked
- Oil level appropriate
- Critical components lubricated
- Overhead obstructions removed
- Screws, bolts, and pins securely fastened
- Surrounding area clean
- Operation, Maintenance, and Safety Manuals on site
- Operational test with a typical vehicle performed

Step 12: Operation Instructions

The owner/employer shall:

- Make sure that lift operators are qualified and that they are trained in the safe use and operation of the lift using the manufacturer's operating instructions; ALI/SM01-1, ALI Lifting It Right safety manual; ALI/ST-90 ALI Safety Tips card; ANSI/ALI ALOIM-2000, American National Standard for Automotive Lifts-Safety Requirements for Operation, Inspection and Maintenance; ALI/WL Series, ALI Uniform Warning Label Decals/Placards; and in the case of frame engaging lifts, ALI/LP-GUIDE, Vehicle Lifting Points/Quick Reference Guide for Frame Engaging Lifts.
- Establish procedures to periodically inspect the lift in accordance with the lift manufacturer's instructions or ANSI/ALI ALOIM-2000, American National Standard for Automotive Lifts-Safety Requirements for Operation, Inspection and Maintenance; and The Employer shall ensure that lift inspectors are qualified and that they are adequately trained in the inspection of the lift.
- Establish procedures to periodically maintain the lift in accordance with the lift manufacturer's instructions or ANSI/ALI ALOIM-2000, American National Standard for Automotive Lifts-Safety Requirements for Operation, Inspection and Maintenance; and The Employer shall ensure that lift maintenance personnel are qualified and that they are adequately trained in the maintenance of the lift.
- Maintain the periodic inspection and maintenance records recommended by the manufacturer or ANSI/ALI ALOIM-2000, American National Standard for Automotive Lifts-Safety Requirements for Operation, Inspection, and Maintenance.
- Display the lift manufacturer's operating instructions; ALI/SM 93-1, ALI Lifting It Right safety manual; ALI/ST-90 ALI Safety Tips card; ANSI/ALI ALOIM-2000, American National Standard for Automotive Lifts-Safety Requirements for Operation, Inspection and Maintenance; and in the case of frame engaging lifts, ALI/LP-GUIDE, Vehicle Lifting Points/Quick Reference Guide for Frame Engaging Lifts; in a conspicuous location in the lift area convenient to the operator.
- Provide necessary lockout/tagout means for energy sources per ANSI Z244.1-1982 (R1993), Safety requirements for the Lockout/Tagout of Energy Sources, before beginning any lift repairs.
- Not modify the lift in any manner without the prior written consent of the manufacturer.
- Make sure that lift maintenance personnel are familiar with ANSI/ALI ALIS, Safety Requirements for Installation and Service of Automotive Lifts.
- Make sure that the lift is not operated unless the operator has read and understood all of the Danger, Warning, and Caution notices in this Installation and Operation Manual.

Lift Operation Safety

- Inspect your lift **DAILY**. Never operate your lift if it malfunctions or if it has broken or damaged parts. Use **only** qualified lift service personnel and genuine BendPak parts to make repairs.
- **THOROUGHLY** train all employees in the use and care of your lift, using manufacturer's instructions and "Lifting It Right" and "Safety Tips" supplied with the lift.
- **NEVER** allow unauthorized or untrained persons to position a vehicle or operate the lift.
- **PROHIBIT** unauthorized persons from being in the shop area while the lift is in use.
- **DO NOT** permit anyone on the lift or inside a vehicle when it is being raised or lowered.
- **ALWAYS** keep the area around the lift free of tools, debris, grease, and oil.
- **NEVER** overload the lift. The capacity of the lift is shown on the nameplate affixed to the lift.
- **DO NOT** stand in front of a vehicle while it is being positioned in the lift bay.



THE LIFT WAS DESIGNED TO RAISE ONLY PASSENGER CARS AND LIGHT DUTY TRUCKS. MANY FULL-SIZE TRUCKS, SPECIALTY, OR MODIFIED VEHICLES CANNOT BE RAISED ON THIS TYPE OF LIFT. CONTACT THE VEHICLE MANUFACTURER FOR RAISING OR JACKING DETAILS. NEVER USE LIFTING ADAPTERS OTHER THAN THOSE SPECIFICALLY DESIGNED FOR THIS LIFT.

- Always use care when loading a vehicle onto the lift. Position the lift adapters to contact at the vehicle manufacturer's recommended lift points. Raise lift until adapters contact vehicle. Check adapters for secure contact with vehicle. Raise lift to desired working height. (See Fig.12.1)

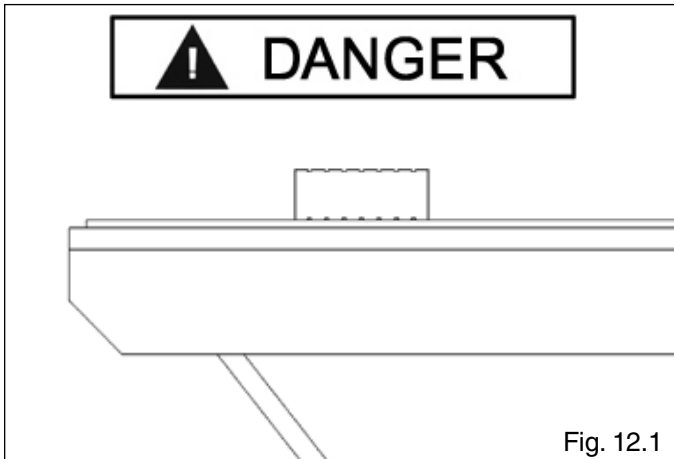

- Do not block open or override self-closing lift controls; they are designed to return to the "Off" or Neutral position when released.
- Always remain clear of lift when raising or lowering vehicles.
- Always use safety stands when removing or installing heavy components.
- Do not go under raised vehicle if safety locks are not engaged.



VISUALLY CONFIRM THAT ALL PRIMARY SAFETY LOCKS ARE ENGAGED BEFORE ENTERING WORK AREA. SUSPENSION COMPONENTS USED ON THIS LIFT ARE INTENDED TO RAISE AND LOWER LIFT ONLY AND ARE NOT MEANT TO BE LOAD HOLDING DEVICES. REMAIN CLEAR OF ELEVATED LIFT UNLESS VISUAL CONFIRMATION IS MADE THAT ALL PRIMARY SAFETY LOCKS ARE FULLY ENGAGED AND THE LIFT IS LOWERED ONTO THE SAFETY LOCKS.

- Never leave lift elevated unless all safety locks are engaged.
- Avoid excessive rocking of vehicle while on lift.
- Clear the area if a vehicle is in danger of falling.

- ALWAYS REMOVE tool trays, stands, and so on before lowering the lift.



WHEN LOWERING THE LIFT, MAKE SURE ALL PERSONNEL AND OBJECTS ARE KEPT CLEAR. KEEP A VISUAL LINE OF SIGHT ON THE LIFT AT ALL TIMES. ALWAYS MAKE SURE THAT ALL LOCKS ARE DISENGAGED. IF ONE OF THE LOCKS INADVERTENTLY LOCKS UPON DESCENT THE VEHICLE MAY DISMOUNT CAUSING PERSONAL INJURY OR DEATH.

- ALWAYS RELEASE safety locks before attempting to lower lift.
- ALWAYS POSITION the lift arms and adapters to provide an unobstructed exit before removing vehicle from lift area.
- NEVER use the lift to raise just one end of the vehicle. Before loading or raising vehicle, be sure all personnel is clear of the lift and surrounding area. Pay careful attention to overhead clearances.

Loading the Lift

NOTE: Before loading a vehicle onto the lift, the lift must be fully lowered and the service bay must be clear of all personnel.



TO AVOID PERSONAL INJURY AND/OR PROPERTY DAMAGE, PERMIT ONLY TRAINED PERSONNEL TO OPERATE LIFT. AFTER REVIEWING THESE INSTRUCTIONS, PRACTICE USING LIFT CONTROLS BY RUNNING THE LIFT THROUGH A FEW UNLOADED CYCLES BEFORE LOADING VEHICLE ON LIFT. ALWAYS LIFT THE VEHICLE USING ALL FOUR ADAPTERS. NEVER RAISE JUST ONE END, ONE CORNER, OR ONE SIDE OF VEHICLE.

1. Make sure the lift is fully lowered.
2. Drive the vehicle onto the lift. Make sure the center-line of the vehicle is positioned properly over the ramps.
3. Set the parking brake or use wheel chocks to hold the vehicle in position.
4. Position any pads underneath the vehicle making sure that they make secure contact with the frame or other recommended lifting point.

Raising the Lift

1. Make sure the vehicle is correctly situated on its lift points before raising it.

Some vehicles have the manufacturer's Service Garage Lift Point locations identified by triangular marks on the undercarriage (reference ANSI/SAE J2184-1992). Also, there may be a label located on the right front door jamb area showing vehicle lift points.

2. Raise the lift by pressing the UP button on the power unit.
3. Raise lift until the vehicle's tires clear the floor.
4. Stop and check to make sure the vehicle is secure and the lifting pads are still in contact with the frame.
5. Continue raising until the vehicle is at the desired height.
6. Raise until the safety lock bars drop into position. (See Fig. 12.2)

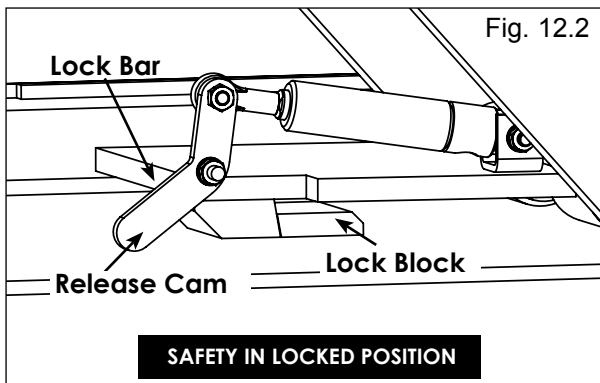

7. Lower the lift onto the nearest safety lock.



VISUALLY CONFIRM THAT ALL PRIMARY SAFETY LOCKS ARE ENGAGED BEFORE ENTERING THE WORK AREA. SUSPENSION COMPONENTS USED ON THIS LIFT ARE INTENDED TO RAISE AND LOWER THE LIFT ONLY AND ARE NOT MEANT TO BE LOAD HOLDING DEVICES. REMAIN CLEAR OF ELEVATED LIFT UNLESS VISUAL CONFIRMATION IS MADE THAT ALL PRIMARY SAFETY LOCKS ARE FULLY ENGAGED AND THE LIFT IS LOWERED ONTO THE SAFETY LOCKS.

Lowering the Lift

1. Remove all tools or other objects from the lift area.
2. Raise the lift at least two inches to provide adequate clearance for the safety to operate.
3. Push the Air Safety Release Button and hold.
4. Visually confirm that the safety bar has been raised up off the safety locks. (See Fig. 12.3)

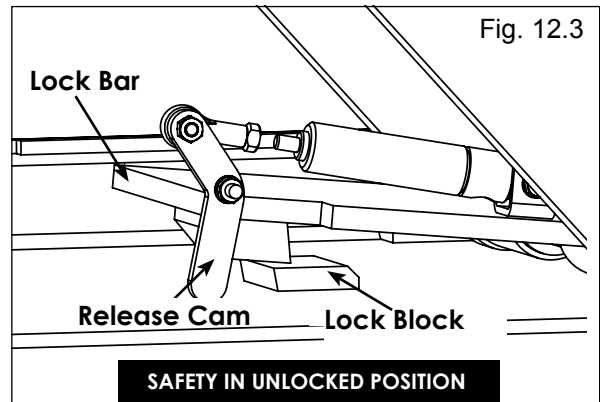

5. Push the LOWERING valve handle to lower.

NOTE: Both the SAFETY LOCK release and the LOWERING valve handles must be held down simultaneously to lower the lift. **Do not override the self-closing lift controls.**



YOU MUST RELEASE THE AIR SAFETY BUTTON WHEN THE LIFT IS 10 INCHES OFF THE GROUND. FAILURE TO DO SO MAY RESULT IN DAMAGE TO THE LIFT'S SAFETY COMPONENTS.

6. Remain clear of the lift when lowering a vehicle. Observe the pinch point warning decals.
7. Continue pressing the Lower handle to fully lower the lift. Remove all lifting adapters before driving the vehicle away.
8. If the lift is not operating properly, do not use it until adjustment or repairs are made by qualified lift service personnel.

MAINTENANCE INSTRUCTIONS

- Always keep bolts tight. Check periodically.
- Always keep lift components clean.
- If oil leakage is observed, always call your local service representative.
- Always call your local service representative if electrical problems develop.
- Replace faulty parts before using the lift.
- **Daily:** Make a visual inspection of *all moving parts* and check for excessive signs of wear.
- **Daily:** Check safety locks to make sure they are in good operating condition.
- **Daily:** Inspect lift pads for damage or excessive wear. Replace as required with genuine BendPak parts.
- **Weekly:** Check all bolts and pins to ensure proper mounting.
- **Monthly:** Lubricate locking latch shafts. Push latch handle several times for oil to penetrate pivot points.
- **Monthly:** Lubricate grease fittings. There are eight: pin receivers on the hydraulic cylinders' rods, base cylinder clevises, main scissor pins, base scissor clevises of inner and outer scissor arms clevises.
- **Every 3 Months:** Check anchor bolt torque. Anchors should be torqued to 90 ft/lbs.
- **Every 6 months:** Check the fluid level of the lift power unit and refill if required per lift installation instructions.
- Replace all Danger, Caution, and Warning decals on the lift if they are difficult to read or missing. Reorder labels from BendPak.
- Refer to the ANSI/ALI ALOIM booklet for a periodic inspection checklist and maintenance log sheet.

SAFE LIFT OPERATION

The safe use of this lift and the other lifts in your shop is critical in preventing employee injuries and damage to customers' vehicles.

Safe operation of your lift requires that only trained employees are allowed to use the lift.

Proper lift training should include the following:

- ◆ Proper positioning of the vehicle on the runway. See manufacturer's minimum wheelbase loading requirements.
- ◆ Use of the operating controls.
- ◆ Understanding the lift capacity.
- ◆ Proper use of jack stands or other load-supporting devices.
- ◆ Proper use, understanding, and visual identification of safety lock devices and their operation.
- ◆ Reviewing the safety rules.
- ◆ Proper housekeeping procedures: lift area should be free of grease, oil, tools, equipment, trash, and other debris.
- ◆ **Daily** inspection of the lift prior to its use. Safety devices, operating controls, lift arms, and other critical parts should be inspected *prior* to using the lift.
- ◆ All maintenance and repairs of the lift should be completed by following the manufacturer's requirements. Lift repair parts should meet or exceed OEM specifications. Repairs should only be completed by a qualified lift technician.
- ◆ The vehicle manufacturer's recommendations should be used for spotting and lifting the vehicle.

SAFE LIFT OPERATION

- ◆ It is important to know your lift's load limit. Be careful that you do not overload the lift. If you are unsure what the load limit is, check the data plate found on the lift or contact the manufacturer.
- ◆ The center of gravity should be followed closely to what the manufacturer recommends.
- ◆ Always make sure you have proper overhead clearance. Additionally, verify that attachments (vehicle signs, camper antennas, and so on) are not in the way.
- ◆ Be sure that prior to the vehicle being raised, the doors, trunk, and hood are securely closed.
- ◆ Prior to raising a vehicle, make sure no one is within 6 feet of the lift.
- ◆ After positioning the vehicle on the lift runways, set the emergency brake, make sure the ignition is off, the doors are closed, overhead obstructions are cleared, and the transmission is in neutral.
- ◆ Double check that the automatic chock devices are in position and then, when the lift is raised, check the chocks.
- ◆ Put pads or adapters in the right position under the recommended contact points.
- ◆ The lift should be raised just until the vehicle's wheels are about one foot off the ground. If contact with the vehicle is uneven or it appears that the vehicle is not sitting securely, carefully lower the lift and readjust.
- ◆ Always consider potential problems that might cause a vehicle to slip; for example, heavy cargo, undercoating, and so on.
- ◆ Pay close attention when walking under a vehicle that is on the lift.



- ◆ **DO NOT** leave the controls while the lift is still in motion.
- ◆ **DO NOT** stand directly in front of the vehicle or in the bay when a vehicle is being loaded or driven into position.
- ◆ **DO NOT** Go near the vehicle or attempt to work on the vehicle while it is being raised or lowered.
- ◆ **REMAIN CLEAR** of the lift when raising or lowering the vehicle.
- ◆ **DO NOT** rock the vehicle while it is on the lift or remove heavy components from the vehicle; this could cause excessive weight shift.
- ◆ **DO NOT** lower the vehicle until people, materials, and tools are clear.
- ◆ **ALWAYS ENSURE** that the safeties are engaged and lowered onto the safety stops before any attempt is made to work on or near the vehicle.
- ◆ Some vehicle maintenance and repair activities may cause the vehicle to shift. Follow the manufacturer's guidelines when performing these operations. The use of jack stands or alternate lift points may be required when completing some repairs.
- ◆ **READ AND UNDERSTAND** all safety warning procedures before operating the lift.
- ◆ **KEEP HANDS AND FEET CLEAR.** Keep your hands and feet away from any moving parts. Keep your feet clear of the lift when lowering a vehicle. Avoid pinch points.

SAFE LIFT OPERATION

- ◆ **ONLY TRAINED OPERATORS** should operate this lift. All non-trained personnel should be kept away from work area. Never let non-trained personnel come in contact with or operate the lift.
- ◆ **USE THE LIFT CORRECTLY.** Always use the lift in the proper manner. Never use lifting adapters other than what is approved by the manufacturer.
- ◆ **DO NOT** override self-closing lift controls.
- ◆ **CLEAR THE AREA IMMEDIATELY** if a vehicle is in danger of falling off the lift.
- ◆ **STAY ALERT.** Watch what you are doing. Use common sense. Be aware.
- ◆ **CHECK FOR DAMAGED PARTS.** Check for alignment of moving parts, breakage of parts, or any condition that may affect its operation. Do not use the lift if any component is broken or damaged.
- ◆ **NEVER** remove safety-related components from the lift. Do not use the lift if safety-related components are damaged or missing.
- ◆ When the lift is being lowered, make sure everyone is standing at least 6 feet away.
- ◆ Before lowering the lift, make sure there are no jacks, tools, or other equipment left under the lift.
- ◆ Always lower the lift slowly and smoothly.



FOR TECHNICAL SUPPORT, PLEASE CALL:
1-(800) 253-2363 Ext. 196

TO ORDER PARTS, PLEASE CALL:
1-(800) 253-2363 Ext. 191

LABELS



LABELS

J

WARNING
FAILURE TO READ AND UNDERSTAND THE FOLLOWING WARNINGS MAY RESULT IN PERSONAL INJURY AND/OR PROPERTY DAMAGE.

| | |
|--------------------------|---------------------------------------|
| Model | MCG-6 Series (2400 Rise) Scissor Lift |
| Maximum Lifting Capacity | 6,000 lbs. / 2722 kg |

OPERATION INSTRUCTIONS

TO RAISE LIFT:

- Clear area of personnel and make sure lift is in full lowered position.
- Drive vehicle over lift making sure center line of the vehicle is positioned properly over lift pads.
- Position lift pads underneath the vehicle making sure that they make secure contact with the factory recommended lifting points.
- Before raising, make sure the weight of the vehicle does not exceed rated capacity of lift.
- Push the **RAISE** button to commence lifting.
- Raise lift until the vehicle is clear of the floor.
- Stop then check if vehicle is secure and the lifting pads are still in contact with the frame.
- Continue raising vehicle to desired height.
- Raise until the safety lock bars drop into the **LOCKED** position as described below in Fig. 4.
- Lower the lift until the **LOCK BARS** rest against the **LOCK BLOCKS**.

TO LOWER LIFT:

- Clear area before lowering lift.
- Lower the lift until the release arms drop into the **UNLOCKED** position as described on Fig. 4.
- Push the **UNLOCKING** button until the lift starts to descend. Stay clear of lift arms.
- Push **AIR ASSIST** button to increase lowering speed after lift pads leave vehicle undercarriage.
- Fully lower the lift and remove all lifting pads before driving vehicle away.

READ AND UNDERSTAND ENTIRE CONTENTS OF OPERATION MANUAL AND WARNINGS BEFORE OPERATING THIS EQUIPMENT.

- Never exceed the rated capacity of the lift.
- DO NOT operate the lift if any component is found to be defective or worn.
- Never operate lift with any person or equipment below.
- Always ensure load is centered and stable prior to operating controls.
- When lowering the lift pay careful attention that all personnel and objects are kept clear.
- Always keep a visual line of site on the lift during operation.
- Always stand clear of lift when lowering or raising.
- Never leave lift in elevated position unless safety lock is engaged in the **LOCKED** position.
- Keep all body parts and objects away from pinch points when lift is in motion.
- Use on level concrete in good condition and free of cracks or other defects.
- Securely confirm safety lock is properly engaged before working on or near lift.

SAFETY FIRST

AIR ASSIST BUTTON

RAISE LIFT OPERATION LOWER

BP BendPak
14425 Linnwood Dr. • Santa Fe, CA 95070
TEL: (925) 424-2000 • www.bendpak.com
© MANUFACTURED BY BENDPAK, USA • MADE IN CANADA

M

CAUTION

Power Unit: Secure placard near lift controls.

Lift Control Console: Secure placard in an accessible location.

Lift to be used by trained operator only.

CAUTION

Authorized personnel only in lift area.

CAUTION

Use vehicle manufacturer's lift points.

CAUTION

Always use safety stands when removing or installing heavy components.

NOTICE

Read operating and safety manuals before using lift.

NOTICE

Proper maintenance and inspection is necessary for safe operation.

NOTICE

Do not operate a damaged lift.

The messages and paragraphs shown are generic in nature and are meant to generally represent hazards common to all automotive lifts regardless of specific type.

Funding for the development and calibration of these labels was provided by the Automotive Lift Institute, PO Box 60, Lombard, NY 14090.

Replacement labels only may be obtained from the original lift manufacturer and ALI member companies. They are protected by copyright.

www.autolift.org
©2012 by ALI, Inc.

K

WARNING

DRIVE CAR COMPLETELY OVER LIFT

NEVER OVERLOAD LIFT
Check for 1" minimum clearance between car and lift before raising.

DO NOT park on or near lift in a fully lowered position or damage may result.

ALWAYS ensure that the safety is in **LOCKED** position before any attempt to make to work on or near the vehicle.

SAFETY IN LOCKED POSITION
(Release Cam disengaged, Lock Bar resting against Lock Block.)

SAFETY IN UNLOCKED POSITION
(Release Cam and Lock Bar elevated and clear Lock Bar disengaged.)

Fig. 4

L

NOTICE

If attachments, accessories, or configuration modifying components used on this lift are located in the load path and affect operation of the lift, affect the lift electrical listing, or affect intended vehicle accommodation; and if they are not certified for use on this lift, then the certification of this lift shall become null and void. Contact the participant for information pertaining to certified attachments, accessories, or configuration modifying components.

www.autolift.org ©2011 by ALI, Inc. ALI / WLSIA01

N

WARNING

This power unit contains a hydraulic pump that is capable of developing pressure in excess of 5,000 psi (345 BAR). A pressure relief valve is used to set the pressure at the desired level. Tampering with, adjusting, modifying, or removing the relief valve is extremely dangerous and is not recommended. Only a trained hydraulics technician, using a calibrated hydraulic pressure gauge to assure the proper pressure setting is achieved, should make adjustments to the relief valve.

WARNING: Changes to the output pressure may render the power unit incompatible with pressure limitations of other components in the hydraulic circuit. This may cause catastrophic failure of those components, and could result in property damage, serious personal injury, or death.

ADVERTENCIA

Esta central hidráulica contiene una bomba capaz de desarrollar una presión en exceso de 5,000 psi (345 BAR). La presión está establecida por la válvula de descarga al nivel de presión deseada. Es extremadamente peligroso y no está recomendado, descomponerla, modificarla o removerla. Solo un técnico cualificado, utilizando un manómetro hidráulico calibrado para asegurar que la propia presión es alcanzada, podrá hacer modificaciones a la válvula de descarga.

ADVERTENCIA: Cambios a la salida de presión, podrían hacer la central hidráulica incompatible con las limitaciones de presión de otros componentes en el circuito hidráulico. Esos componentes podrían funcionar mal causando una catástrofe y podría resultar en daño a la propiedad, serio daño personal o muerte.

WARNING

Dieses Hydraulikaggregat beinhaltet eine Pumpe, welche einen Betriebsdruck bis zu 345 bar aufbauen kann. Ein integriertes Druckbegrenzungsventil begrenzt diesen Betriebsdruck. Missbrauch, verändern der Druckeinstellung, technische Veränderungen oder entfernen des Ventils, sind extrem gefährlich und daher nicht zu empfehlen. Nur qualifiziertes Personal mit Hydraulik Erfahrung, sollte unter Verwendung eines kalibrierten Manometers den Druck dieses Sicherheitsventils einstellen.

WARNUNG: Eine Veränderung des Betriebsdruckes am Aggregat, kann zu Problemen bei anderen angeschlossenen Komponenten führen, welche nur über einen geringeren zulässigen Betriebsdruck verfügen. Dies kann zur vollständigen Zerstörung dieser Geräte führen und zusätzlich zu schweren Verletzungen oder sogar zu Lebensgefahr beim Bedienpersonal führen.

AVERTISSEMENT

Cet équipement utilise une pompe hydraulique capable de fournir une pression de 345 bar. Une soupape de sûreté est utilisée pour régler la pression à la valeur souhaitée. Altérations, réglages, modifications ou suppression de cette soupape de sûreté peuvent se révéler très dangereux et ne sont absolument pas recommandés. Uniquement un hydraulicien qualifié, utilisant un manomètre pour permettre l'affichage précis de la pression, pourra assurer les réglages de la soupape de sûreté.

AVERTISSEMENT: Tout changement de la valeur de la pression de sortie peut rendre incompatible l'utilisation de cet équipement avec les autres composants du circuit hydraulique. Ceux-ci peuvent être endommagés de manière définitive et peuvent causer des dégâts matériels, ainsi que des risques de blessures sérieuses ou la mort.

LABELS

O

⚠ WARNING ⚠



Always allow a minimum 2-second delay between motor starts. Failure to comply may cause switch and/or motor burnout. This could cause serious damage to the equipment and/or personal property.

RISK OF EXPLOSION

This equipment has internal arcing or sparking parts which should not be exposed to flammable vapors.

DO NOT LOCATE IN A RECESSED AREA OR BELOW FLOOR LEVEL.

P

| | | | | | |
|------------------------------|-------------------------|---------------|---|---------|--|
| SKU NO: 5585280 | | Ranger | | TENV | |
| HP: 2.0 | I.D. NO: ST-001-PROTO | VOLT: 208 | V: 240 | | |
| Hz: 50/60 | RPM: 2880/3450 | KVA: L | FLA: 15 | FLA: 20 | |
| PH: 1 | NOT THERMALLY PROTECTED | EFF%: 80 | SFA: 1 | SFA: 1 | |
| FRAME: 56 | DUTY: 5 MIN | DES: 56 | <small>WARNING: GROUNDING - Failure to connect the motor frame to equipment grounding conductor by using the grounding cord, green screw, or green wire provided, may result in serious electric shock.</small> | | |
| TYPE: | MAX. AMB. °C: 40 | PRV: 2850 |  | | |
| DATE: | INS CLASS: F | CODE: |   | | |
| <small>MADE IN CHINA</small> | | | | | |

Q

⚠ CAUTION ⚠

(1) MOTOR NOT PROTECTED - EXTERNAL OVERHEAT PROTECTION IN ACCORDANCE WITH CE CODE, PART 1, SHALL BE PROVIDED.
(2) MINIMUM CIRCUIT AMPACITY OF CONDUCTOR IS 30A

⚠ PRECAUCIÓN ⚠

(1) MOTOR NO ESTÁ PROTEGIDO - SE PROVEERÁ PROTECCIÓN CONTRA SOBRECALENTAMIENTO EXTERNO DE CONFORMIDAD CON EL CÓDIGO CE, SECCIÓN 1.
(2) AMPACIDAD MÍNIMO DEL CONDUCTOR DEL CIRCUITO ES 30A

⚠ ATTENTION ⚠

(1) MOTEUR NON PROTEGE - PROTECTION EXTERIEURE CONTRE LA SURCHAFFE DOIT ETRE ASSUREE CONFORMEMENT AU CODE CE PREMIERE PARTIE.
(2) COURANT ADMISSABLE MINIMAL DE LA DERIVATION 30A

**Maximum Run Time: 100 Seconds.
Off Time: 500 Seconds.
Total: 600 Seconds.**

If connected to a circuit protected by fuses use time-delay fuse Marked D

Si está conectado a un circuito protegido por fusibles, utilice fusibles de acción retardada, tipo D

Si connecté à un circuit protégé par fusibles utilisez fusible temporisé Marqué D

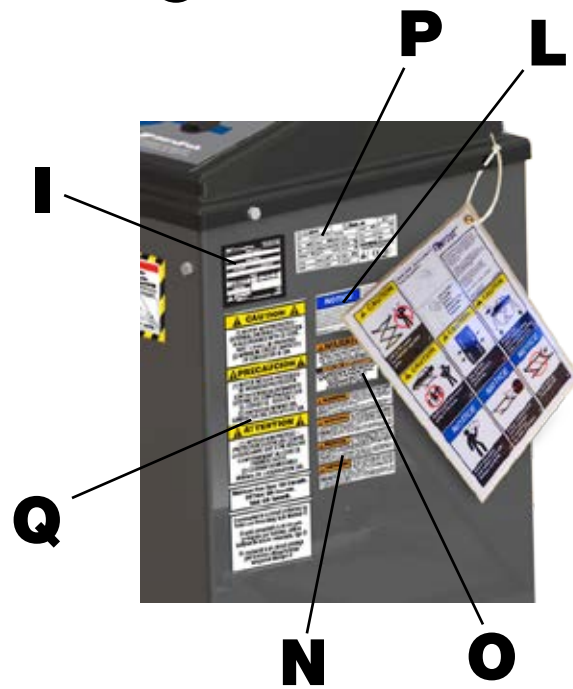
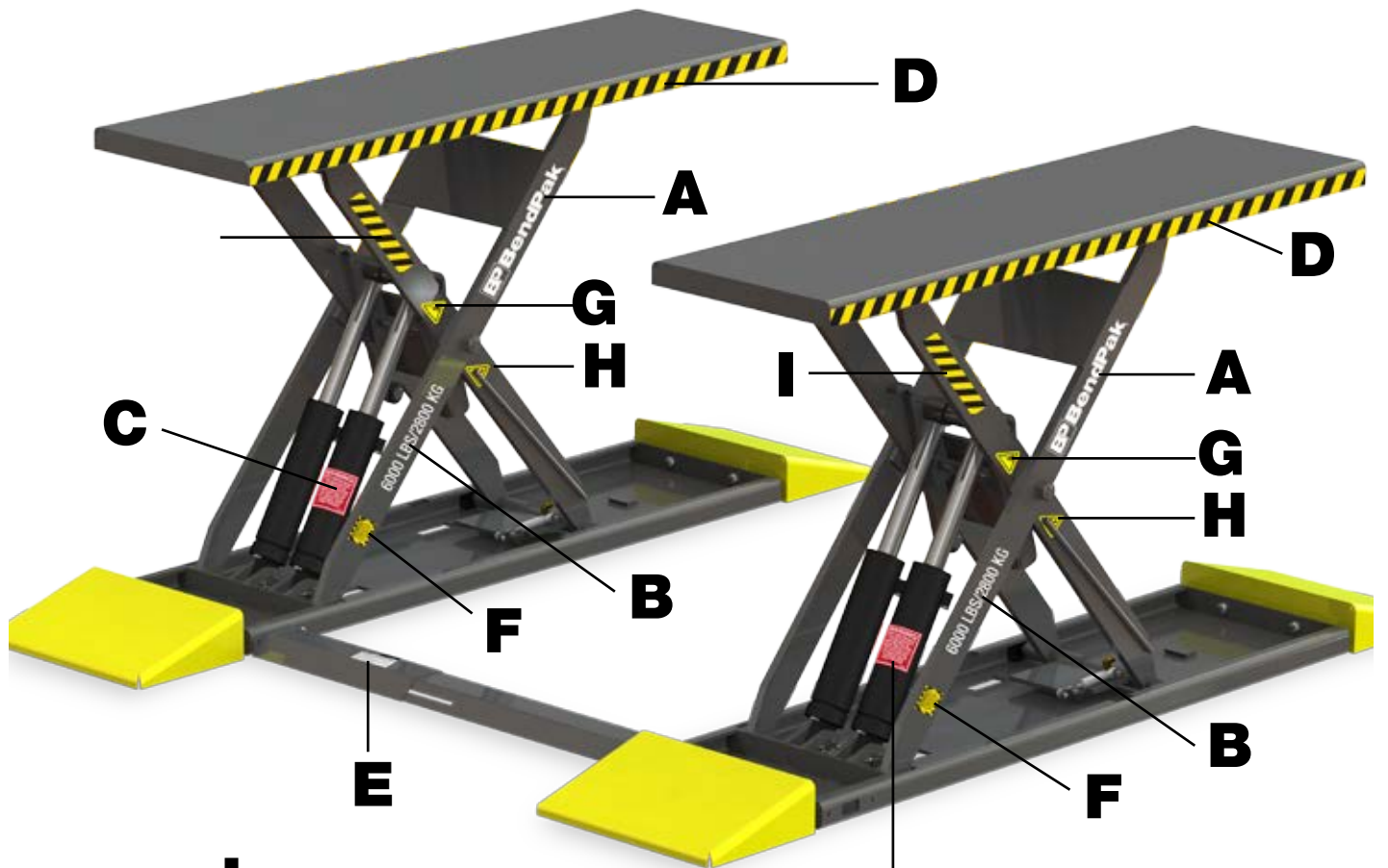

Troubleshooting

Issue: Lift Will Not Raise

Possible Causes with Solution Numbers

- Air in oil ... 1, 2, 8, 13
- Cylinder binding ... 9
- Cylinder leaks internally ... 9
- Motor run backward under pressure ... 11
- Lowering valve leaks ... 3, 4, 6, 10, 11
- Motor runs backwards ... 7, 14, 11
- Pump damaged ... 10, 11
- Pump won't prime ... 1, 8, 13, 14, 3, 12, 10, 11
- Relief valve leaks ... 10, 11
- Voltage to motor incorrect ... 7, 14, 11

| Solutions | Action to Take |
|--|--|
| 1. Check for proper oil level in the reservoir with the left all the way down. | The oil level should be up to the bleed screw. |
| 2. Bleed cylinders. | Refer to the appropriation section of the Installation and Operation Manual. |
| 3. Flush release valve to get rid of possible contamination. | Hold down the release handle and start the unit, allowing it to run for 15 seconds. |
| 4. The oil is dirty. | Replace the existing oil with clean Dexron ATF fluids, such as Dexron III, Dexron VI, Mercon V, Mercon LV or comparable. |
| 5. Tighten all fasteners. | Tighten fasteners to recommended torques. |
| 6. Check for free movement of release. | If the handle does not move freely, replace the bracket or handle assembly. |
| 7. Make sure motor is wired correctly. | Compare wiring of motor to electrical diagram on drawing. |
| 8. The oil seal is damaged or cocked. | Replace the oil seal around the pump shaft. |
| 9. Refer to the Installation and Operation Manual. | Check the Installation and Operation Manual. |
| 10. Replace with a new part. | Replace with a new part. |
| 11. Return the unit for repair. | Return unit for repair. |
| 12. Check the pump-mounting bolts. | Bolts should be 15 to 18 lbs / ft. |
| 13. The inlet screen is clogged. | Clean inlet screen or replace. |
| 14. Check wall outlet voltages and wiring. | Make sure unit and wall outlet are wired properly. |

Issue: Motor Will Not Run

Possible Causes with Solution Numbers

- Fuse blown ... 5, 2, 1, 3, 4
- Limit switch burned out ... 1, 2, 3, 4
- Microswitch burned out ... 1, 2, 3, 4
- Motor burned out ... 1, 2, 3, 4, 6
- Voltage to motor incorrect ... 2, 1, 8

| Solutions | Action to Take |
|--|---|
| 1. Check for correct voltage. | Compare supply voltage with voltage on motor name tag. Check that the wire is sized correctly. N.E.C. table 310-12 requires AWG 10 for 25 Amps. |
| 2. Make sure motor is wired correctly. | Compare wiring of motor to electrical diagram on drawing. |
| 3. Do not use extension cords. | According to N.E.C. "The size of the conductors ... should be such that the voltage drop would not exceed 3% to the farthest outlet for power" |
| 4. Replace with new part. | Replace with new part. |
| 5. Reset circuit breaker/fuse. | Reset circuit breaker/fuse. |
| 6. Return unit for repair. | Return unit for repair. |
| 7. Refer to the Installation and Operation Manual. | Check the Installation and Operation Manual. |
| 8. Check wall outlet voltage and wiring. | Make sure unit and wall outlet are wired properly. The motor must run at 208/230 VAC. |

Issue: Lift Lowers Slowly or Not At All

Possible Causes with Solution Numbers

- Cylinders binding ... 1
- Release valve clogged ... 5, 4, 2, 3
- Pressure fitting too long ... 6

| Solutions | Action to Take |
|--|---|
| 1. Refer to the Installation and Operation Manual. | Check the Installation and Operation Manual. |
| 2. Replace with new part. | Replace with new part. |
| 3. Return for repair. | Return for repair. |
| 4. Check oil. | Use clean 10 WT hydraulic oil or Dexron-III automatic transmission fluid only. If ATF is contaminated, replace with clean ATF and clean entire system. You can use Dexron III, Dexron VI, Mercon V, Mercon LV, or comparable. |
| 5. Clean release valve. | Wash release valve in solvent and blow out with air. |
| 6. Replace fitting with short thread lead. | Replace fitting with short thread lead. |

Issue: Lift Will Not Raise When Loaded

Possible Causes with Solution Numbers

- Air in oil ... 1, 2, 3, 4
- Cylinder binding ... 5
- Cylinder leaks internally ... 5
- Lift is overloaded ... 6, 5
- Lowering valve leaks ... 7, 8, 1, 5, 9
- Motor runs backwards ... 10, 12, 9
- Pump damaged ... 5, 9
- Pump won't prime ... 1, 2, 3, 4, 5, 11, 9
- Relief valve leaks ... 8, 5, 9
- Voltage to motor incorrect ... 10, 12, 5

| Solutions | Action to Take |
|--|--|
| 1. Check the oil level. | The oil level should be up to the bleed screw in the reservoir (with the lift all the way down). |
| 2. Check/tighten inlet tubes. | Replace the inlet hose assembly. |
| 3. Oil seal damaged or cocked. | Replace the oil seal and install. |
| 4. Bleed cylinders | Refer to the appropriate section of the Installation and Operation Manual. |
| 5. Refer to the Installation and Operation Manual. | Check the Installation and Operation Manual. |
| 6. Check the weight of the vehicle. | Make sure the weight limit of the limit can accommodate the weight of the vehicle. |
| 7. Flush the release valve. | Hold the release handle down and start the unit, allowing it to run for 15 seconds. |
| 8. Replace with a new part. | Replace with a new part. |
| 9. Return the unit for repair. | Return the unit for repair. |
| 10. Make sure the motor is wired correctly. | Compare wiring of motor to electrical diagram on drawing. |
| 11. Inlet screen clogged. | Clean the inlet screen or replace it. |
| 12. Check wall outlet voltage and wiring. | Make sure the unit and wall outlet are wired properly. |

IMPORTANT: If the vehicle becomes stranded in the air, follow the operation instructions on pages 21 – 23. If after observing that all mechanical locks are released and the lift still fails to move following all standard operating procedures, immediately stop using the lift and contact the factory or a factory-approved service center for further instructions.





Issue: Lift Will Not Stay Up

Possible Causes with Solution Numbers

- Air in oil ... 1, 2, 3
- Valves are leaking ... 6
- Cylinders leak internally ... 7
- Lowering valve leaks ... 4, 5, 1, 7, 6
- Fittings are leaking ... 8

| Solutions | Action to Take |
|--|--|
| 1. Check oil level. | The oil level should be up to the bleed screw in the reservoir with the lift all the way down. |
| 2. Oil seal damaged and cocked. | Replace oil seal around pump shaft. |
| 3. Bleed cylinder. | Refer to the Installation and Operation Manual. |
| 4. Flush release valve. | Hold release handle down and start unit, allowing it to run for 15 seconds. |
| 5. Replace with new valve. | Replace with new valve. |
| 6. Return unit for repair. | Return unit for repair. |
| 7. Refer to the Installation and Operation Manual. | Check the Installation and Operation Manual. |
| 8. Check complete hydraulic system for leaks. | Tighten all hydraulic fittings and inspect all hoses. |

Torque Recommendations

| VALUES ARE STATED IN FOOT POUNDS (ft-lb) | | | | | |
|--|---------------------------|---|---|--|---|
| | |  |  |  |  |
| | | SAE 0-1-2 | SAE Grade 5 | SAE Grade 8 | SOCKET HEAD CAP SCREW |
| | | CLASS 4.8 | CLASS 8.8 | CLASS 10.9 | CLASS 12.9 |
| Bolt Size (SAE) | Bolt Size (Metric) | | | | |
| 1/4-20 | M6 x 1.0 | 6 | 10 | 14 | 13 |
| 5/16-18 | M8 x 1.25 | 12 | 19 | 29 | 31.4 |
| 3/8-16 | M10 x 1.50 | 20 | 33 | 47 | 62 |
| 7/16-14 | | 32 | 54 | 78 | |
| 1/2-13 | M12 x 1.75 | 47 | 78 | 119 | 108 |
| 9/16-12 | M14 x 2.00 | 69 | 114 | 169 | 173 |
| 5/8-11 | M16 x 2.00 | 96 | 154 | 230 | 269 |
| 3/4-10 | M18 x 2.50 | 155 | 257 | 380 | 372 |
| 7/8-9 | M22 x 2.50 | 206 | 382 | 600 | 716 |
| 3/4 Anchor Bolts | | 75 MIN 110 MAX | | | |

INSTALLATION FORM

| | | | |
|---|---|-----------------------|-------|
| Customer Name: | | Date of Installation: | |
| Company Name: | | | |
| Street Address: | | | |
| City: | State: | Zip: | |
| Phone: | | Fax: | |
| Pre-Install Agreement | | | |
| <p>I, (the undersigned) acting as the owner of the business listed above assume responsibility for any permits required, either state or county mandated, related to the installation and/or operation of this equipment. I assume responsibility for the concrete floor and condition thereof, now or later, where the above equipment model(s) are installed. I will assume all liability for losses, damages (including loss of use), expenses, demands, claims, and judgments in connection with or arising out of any personal injury or alleged damage to property, sustained or alleged to have been sustained in connection with, or to have arisen out of the condition and/or drilling of the concrete near or adjacent to the equipment model(s) listed above. If my employee(s) offer assistance of any kind during installation of the above equipment model(s) I hold the manufacturer and installation company harmless of all liability for losses, damages, expenses, claims, and judgments in connection with or arising out of any personal injury or alleged damage to property, sustained or alleged to have been sustained in connection with the installation of the above equipment model(s).</p> <p>I understand that the lifts above are supplied with concrete fasteners meeting the criteria of the American National Standard "Automotive Lifts - Safety Requirements for Construction, Testing, and Validation" ANSI/ALI ALCTV-1998, and that I will be responsible for all charges related to any special regional structural and/or seismic anchoring requirements specified by any other agencies and/or codes such as the Uniform Building Code (UBC) and/or International Building Code (IBC).</p> | | | |
| Customer Signature: | | Print Name: | Date: |
| Post-Installation Check-Off | | | |
| <input type="checkbox"/> Base and Columns Properly Shimmed And Stable | <input type="checkbox"/> Lubrication of Critical Components | | |
| <input type="checkbox"/> Anchor Bolts Tightened | <input type="checkbox"/> Lift Adapters | | |
| <input type="checkbox"/> Runways Properly Attached and Secured | <input type="checkbox"/> Check For Overhead Obstructions | | |
| <input type="checkbox"/> Electric Power Supply Confirmed | <input type="checkbox"/> Runways Level | | |
| <input type="checkbox"/> Cables / Chains Adjusted Properly | <input type="checkbox"/> All Screws, Bolts, and Pins Secured | | |
| <input type="checkbox"/> Safety Locks Functioning Properly | <input type="checkbox"/> Surrounding Area and Lift Clean In Appearance | | |
| <input type="checkbox"/> Check For Hydraulic Leaks | <input type="checkbox"/> Proper Operation, Maintenance and Safety Explained | | |
| <input type="checkbox"/> Oil Level | <input type="checkbox"/> Operation and Safety Manual(s) Left at Site | | |
| <p>I, (the undersigned) confirm that the above installation procedure(s) were completed. I understand that I will be responsible for maintaining this equipment as outlined in the accompanied <i>Installation and Operation Manual</i> and <i>ANSI/ALI ALOIM Safety Requirements for Operation, Inspection and Maintenance</i>. I understand that personal injury and/or damage to property can occur if the above equipment model(s) are not maintained or used improperly and take full responsibility for training my employees on proper use and maintenance of this equipment. I hold the manufacturer and installation company harmless of all liability for losses, damages (including loss of use), expenses, demands, claims, and judgments in connection with or related to improper use, improper training, or lack of required maintenance. I understand that the warranty does not cover replacement of parts worn or damaged due to normal use or lack of required maintenance</p> | | | |
| Customer Signature: | | Print Name: | Date: |
| Installer Signature: | | Print Name: | Date: |
| Installer Company Name: | | | |
| Street Address: | | | |
| City: | State: | Zip: | |
| Phone: | | Phone (Other): | |

| REVISION | | | |
|----------|-------------------------------------|------------|----------------|
| REV | DESCRIPTION | DATE | EDITED BY/ECO# |
| D | ADDED 5601106, UPDATED BOM REVISION | 10/21/2016 | TS 00781 |
| E | UPDATED BOM REVISIONS | 12/09/2016 | TS 00794 |
| F | UPDATED BOM REVISIONS | 12/23/2016 | TM 00797 |

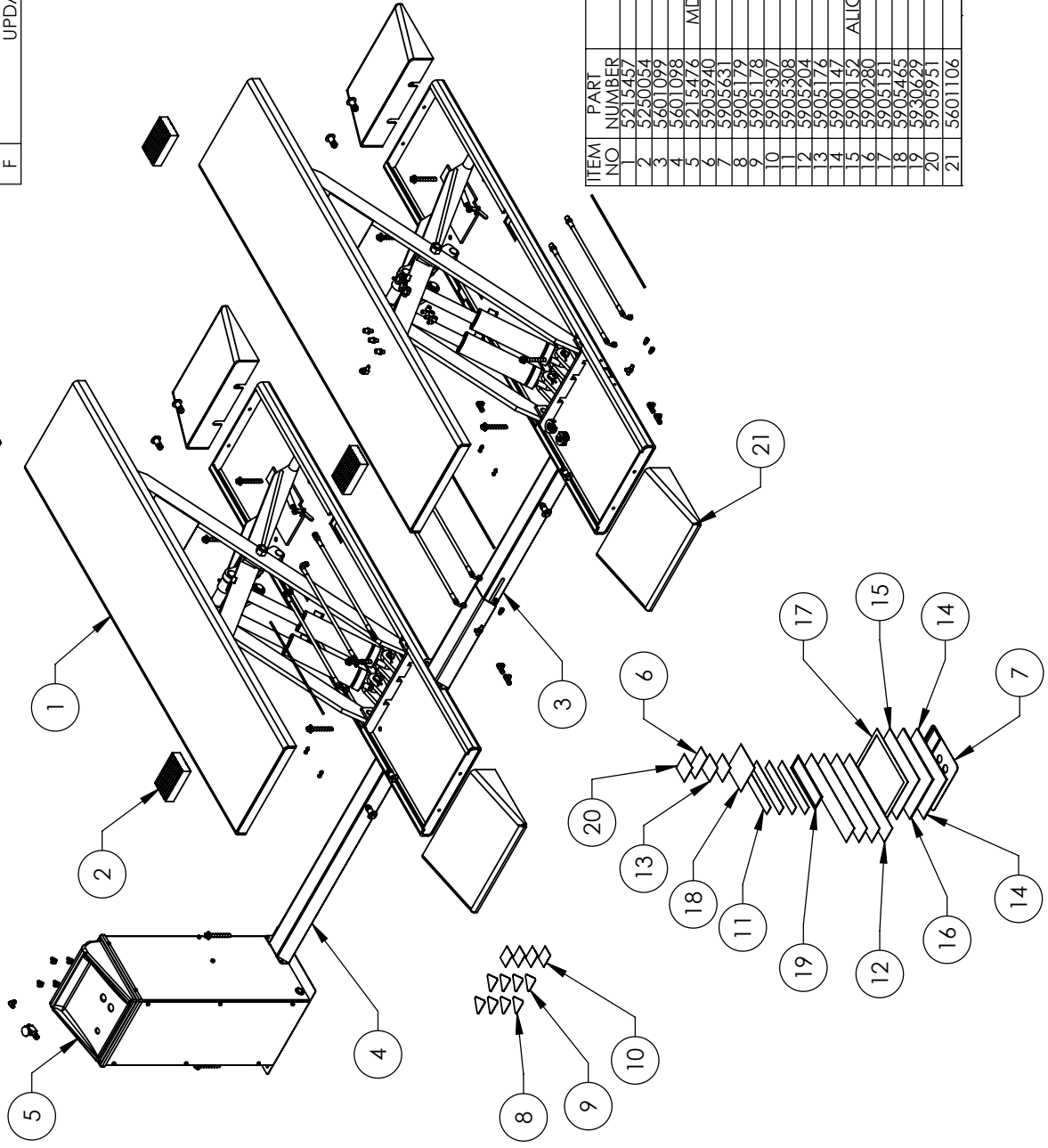

| ITEM NO | PART NUMBER | DESCRIPTION | QTY | REV |
|---------|-------------|---|-----|-----|
| 1 | 5215457 | MDS-6EX RAMP ASSEMBLY | 2 | F |
| 2 | 5240034 | MDS-6EXT PARIS BOX | 1 | D |
| 3 | 5601099 | MDS-6EXT INNER FLOOR TROUGH WELDMENT | 1 | B |
| 4 | 5601098 | MDS-6EXT OUTER FLOOR TROUGH WELDMENT | 1 | B |
| 5 | 5215476 | MDS-6EXT POWER UNIT CONSOLE ASSEMBLY, SHORT | 1 | A |
| 6 | 5905940 | PRODUCT DATA LABEL | 1 | -- |
| 7 | 5905631 | MDS-6K CONSOLE PANEL WARNING LABEL | 1 | A |
| 8 | 5905179 | WARNING/CRUSH POINT LABEL | 4 | -- |
| 9 | 5905178 | WARNING/LUBE POINT LABEL | 4 | -- |
| 10 | 5905307 | CAUTION CAPACITY SCISSOR LIFT | 4 | -- |
| 11 | 5905308 | MDS-6K CAPACITY LABEL | 4 | -- |
| 12 | 5905204 | BENDPAK LABEL | 4 | -- |
| 13 | 5905176 | WARNING TO PROLONG LIFE | 2 | -- |
| 14 | 5900147 | SAFETY MANUAL ALL/SM 93-1 | 1 | -- |
| 15 | 5900152 | ALIGN OIM OPERATIONAL SECTION & MAINTENANCE | 1 | -- |
| 16 | 5900280 | ALIGN OIM OPERATIONAL SECTION & MAINTENANCE | 1 | -- |
| 17 | 5905151 | ALIGN OIM OPERATIONAL SECTION & MAINTENANCE | 1 | -- |
| 18 | 5905465 | SAFETY TIPS CARD ALL/ST 90 | 1 | -- |
| 19 | 5930679 | MANUFACTURER LABEL | 1 | -- |
| 20 | 5905951 | MDS-6K WARNING DRIVE OVER LABEL | 1 | -- |
| 21 | 5601106 | MDS-6K DRIVE UP RAMP WELDMENT, SHORT | 4 | C |

BendPak.
 1645 LEMONWOOD DR.
 SANTA PAULA, CA 93060

TITLE: MDS-6EXT PRODUCTION
LIFT VER B

SIZE DWG. NO. **A** 5260556 REV **F**

SCALE: 1:25 SHEET 1 OF 3

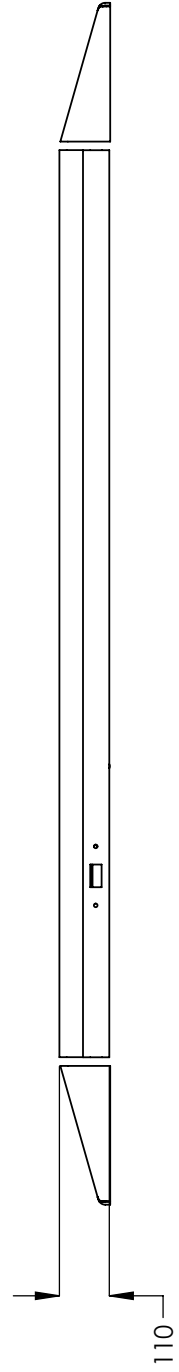
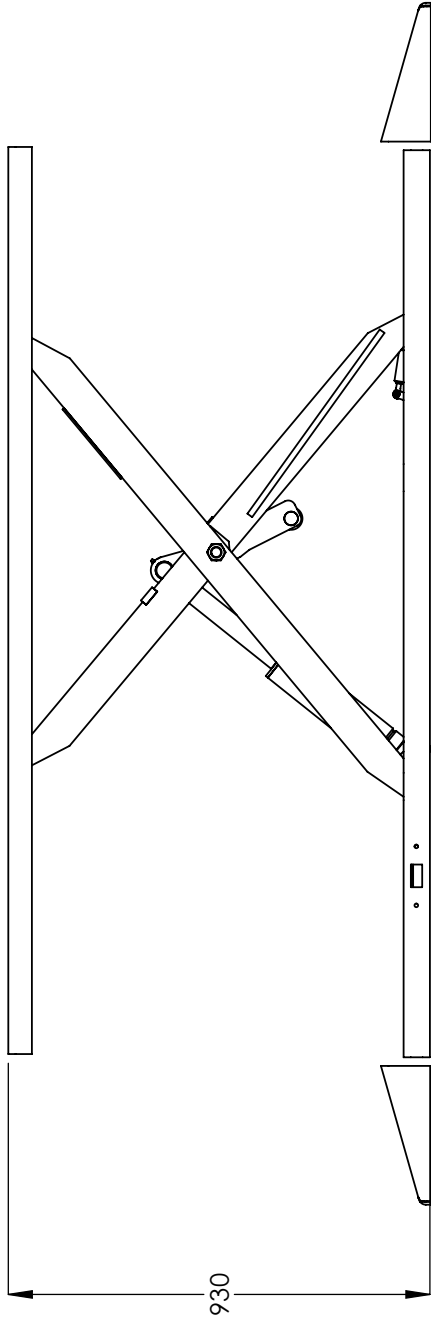

| | |
|--|----------|
|  BendPak. 1445 LEMONWOOD DR. SANTA PAULA, CA 93060 | |
| TITLE: MDS-6EXT PRODUCTION LIFT VER B | |
| SIZE DWG. NO. | REV |
| A 5260556 | F |
| SCALE: 1:16 | |
| SHEET 2 OF 3 | |

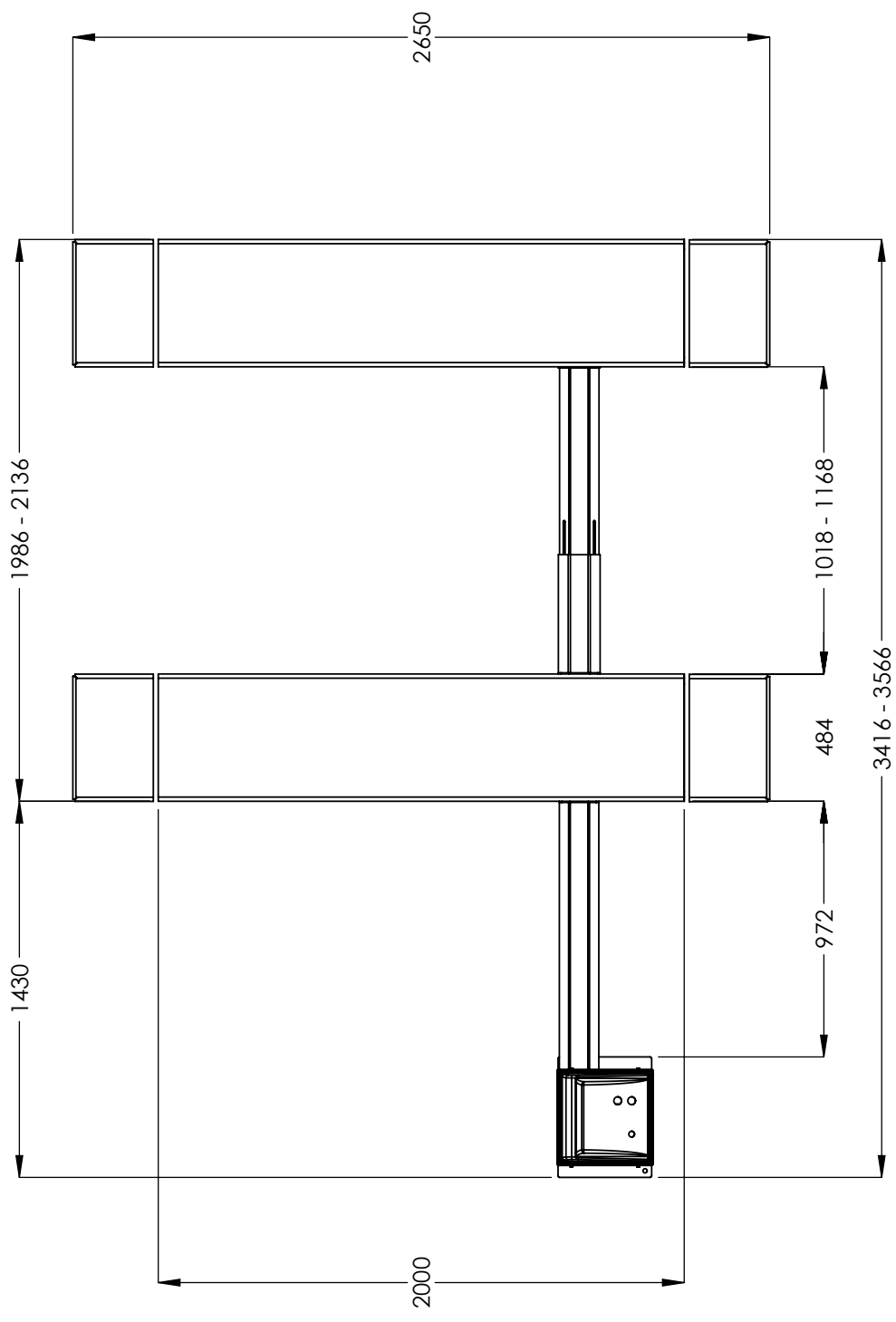

BP BendPak.

1645 LEMONWOOD DR.
SANTA PAULA, CA 93060

TITLE: MDS-6EXT PRODUCTION
LIFT VER B

| | | |
|----------|----------|-----|
| SIZE | DWG. NO. | REV |
| A | 5260556 | F |

SCALE: 1:25 SHEET 3 OF 3

| REVISION | | | |
|----------|--|------------|----------------|
| REV | DESCRIPTION | DATE | EDITED BY/ECO# |
| B | UPDATED BOM REVISION | 10/05/2016 | TS 00781 |
| C | REPLACED 5570060 WITH 5570911, UPDATED BOM REVISIONS | 12/09/2016 | TS 00794 |
| D | UPDATED BOM REVISION | 12/27/2016 | TM 00797 |

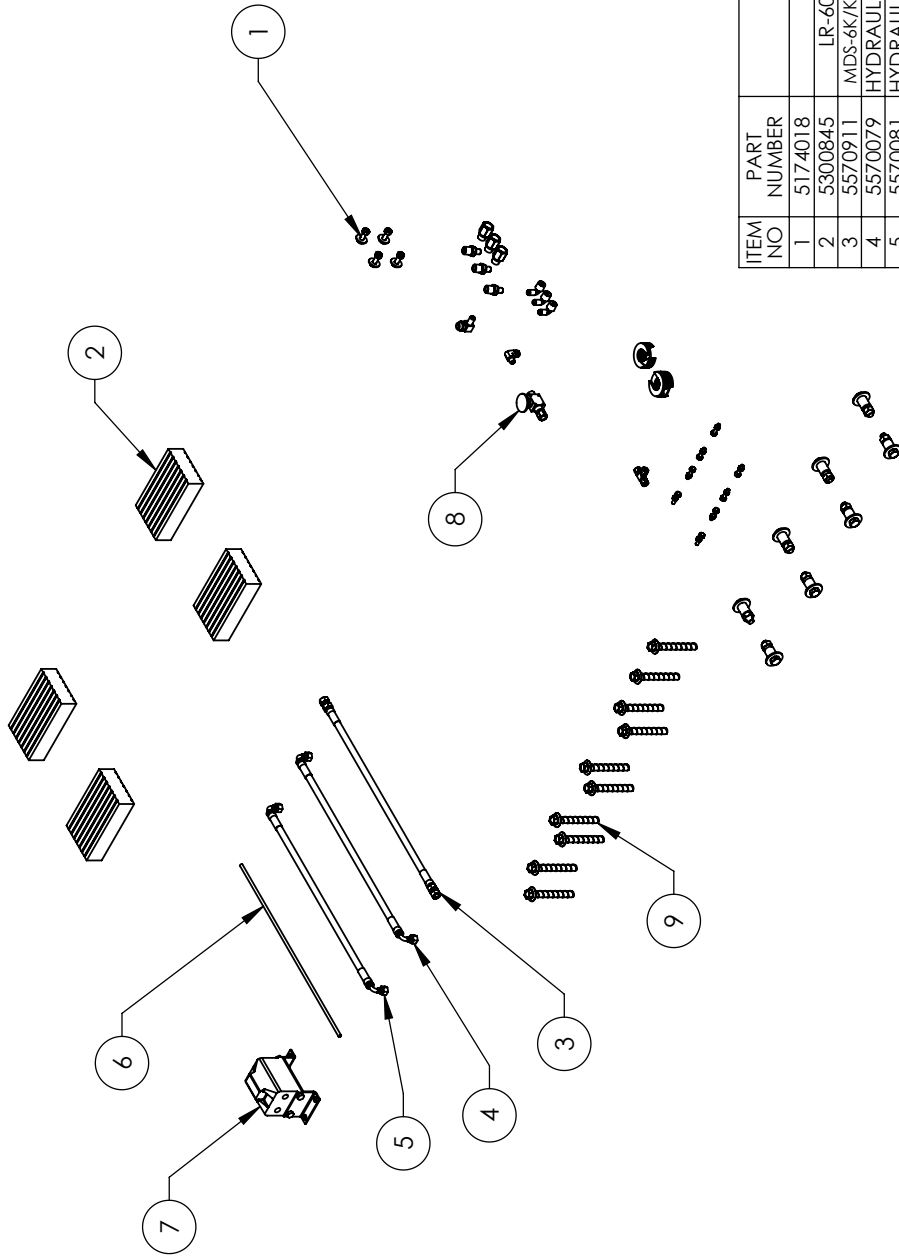

| ITEM NO | PART NUMBER | DESCRIPTION | QTY | REV |
|---------|-------------|--|---------|-----|
| 1 | 5174018 | MDS-6K PARTS BAG | 1 | D |
| 2 | 5300845 | LR-60/60P_P-6 38mm (1.5") RUBBER PAD | 4 | A |
| 3 | 5570911 | MDS-6K/KF HYDRAULIC HOSE ASSY Ø6.35 x 458mm DS | 1 | A |
| 4 | 5570079 | HYDRAULIC HOSE ASSEMBLY Ø6.35 x 2212mm DB | 1 | B |
| 5 | 5570081 | HYDRAULIC HOSE ASSEMBLY Ø6.35 x 3352mm DB | 1 | B |
| 6 | 5570795 | 1/4" POLY-FLO TUBING | 3550mm* | -- |
| 7 | 5590135 | HYDRAULIC FLOW DIVIDER | 1 | -- |
| 8 | 5590175 | PUSH BUTTON AIR VALVE | 1 | -- |
| 9 | 5530325 | 1/2" x 4" SCREW ANCHOR, CONCRETE | 10 | -- |

| | | |
|---|----------|--------------|
| DRAWN | TM | 07/26/2016 |
| CHECKED | DB | 1/4/2017 |
| THIRD ANGLE PROJECTION | | |
| | | |
| | | |
| 1645 LEMONWOOD DR. SANTA PAULA, CA 93060 | | |
| TITLE: MDS-6EXT PARTS BOX | | |
| SIZE | DWG. NO. | REV |
| A | 5250054 | D |
| SCALE: 1:15 | | SHEET 1 OF 1 |

PROPRIETARY AND CONFIDENTIAL
THIS DRAWING IS THE SOLE PROPERTY OF BENDPAK INC. ANY
REPRODUCTION OR TRANSMISSION OF THIS DRAWING
WITHOUT THE WRITTEN PERMISSION OF BENDPAK INC. IS
PROHIBITED.

| REVISION | | | |
|----------|--|------------|-----------|
| REV | DESCRIPTION | DATE | EDITED BY |
| A | PRODUCTION RELEASE, DERIVED FROM 5215424 | 07/27/2016 | TM |
| | | | ECO# |
| | | | 00768 |

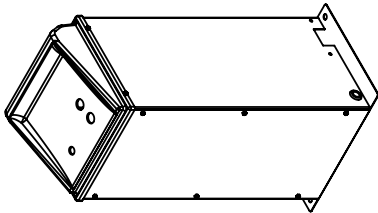

ISOMETRIC VIEW
FOR REFERENCE ONLY
DO NOT SCALE

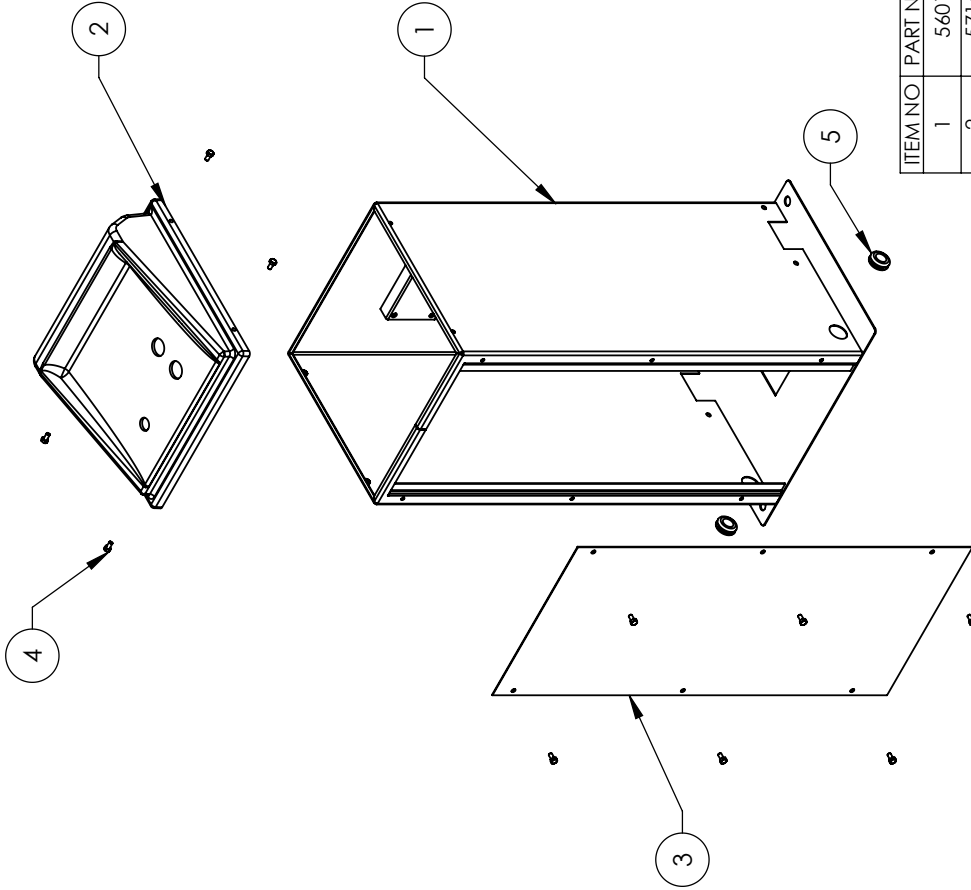

| ITEM NO | PART NUMBER | DESCRIPTION | QTY | REV |
|---------|-------------|---|-----|-----|
| 1 | 5601022 | MDS-6 SERIES POWER UNIT CONSOLE WELDMENT, SHORT | 1 | B |
| 2 | 5716018 | POWER UNIT CONSOLE COVER | 1 | B |
| 3 | 5736895 | POWER UNIT CONSOLE DOOR, SHORT | 1 | A |
| 4 | 5530031 | HHB M6 x 1 x 12 | 10 | -- |
| 5 | 5520001 | RUBBER GROMMET, 3/4 I.D. | 2 | A |

| | | | | |
|------------------------|----|------------|---|----------|
| DRAWN | TM | 07/27/2016 | 1645 LEMONWOOD DR. BendPak SANTA PAULA, CA 93060 | |
| CHECKED | DB | 09/26/2016 | | |
| THIRD ANGLE PROJECTION | | | TITLE: MDS-6EXT POWER UNIT CONSOLE ASSEMBLY, SHORT | |
| | | | SIZE | DWG. NO. |
| | | | A | 5215476 |
| | | | REV | A |
| | | | SCALE: 1:12 | |
| | | | SHEET 1 OF 1 | |

PROPRIETARY AND CONFIDENTIAL
THE INFORMATION CONTAINED IN THIS DRAWING IS
THE SOLE PROPERTY OF BENDPAK INC. ANY
REPRODUCTION OR TRANSMISSION WITHOUT
THE WRITTEN PERMISSION OF BENDPAK INC. IS
PROHIBITED.

REVISION

| REV | DESCRIPTION | DATE | EDITED BY | ECO# |
|-----|--|------------|-----------|-------|
| A | PRODUCTION RELEASE, DERIVED FROM 5261000 | 01/26/2016 | TM | 00746 |
| B | UPDATED BOM REVISION | 10/31/2016 | TS | 00781 |
| C | REMOVED 524541 4, UPDATED BOM REVISION | 12/12/2016 | TS | 00794 |

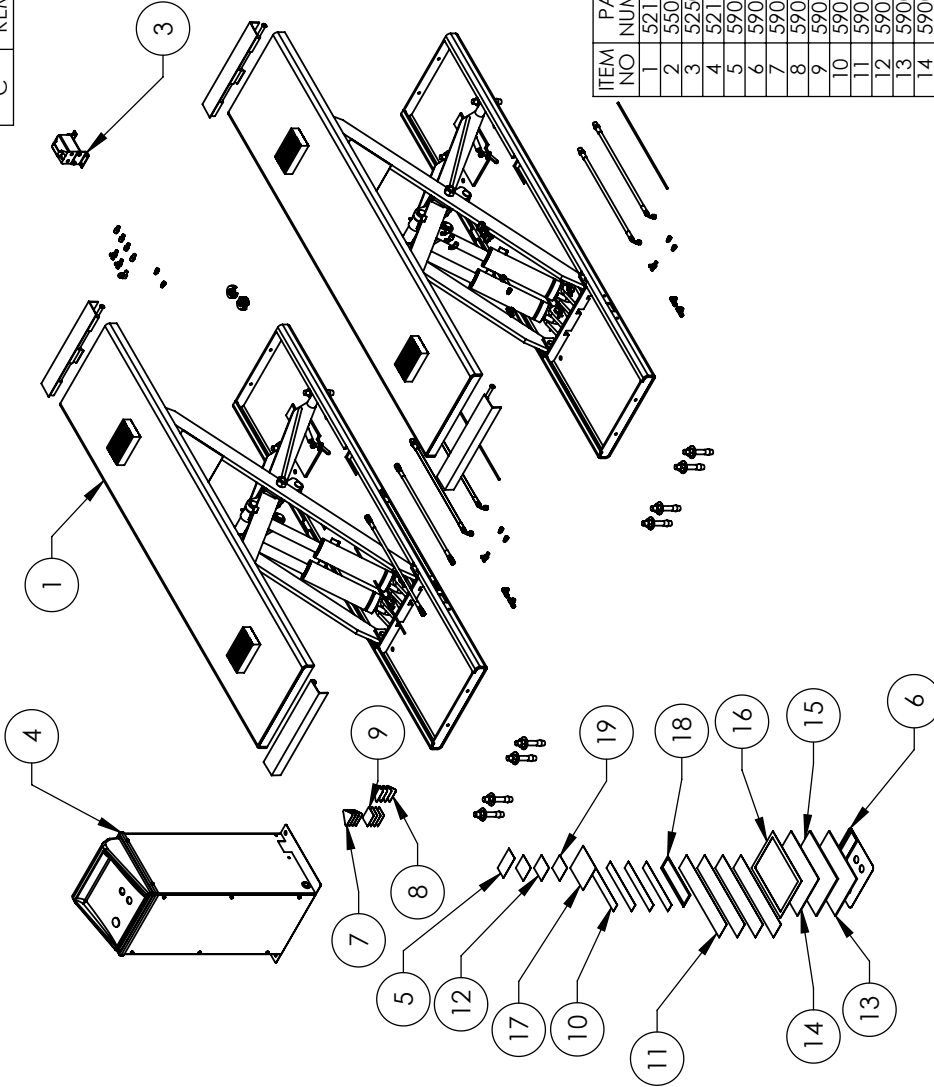

| ITEM NO | PART NUMBER | DESCRIPTION | QTY | REV |
|---------|-------------|--|-----|-----|
| 1 | 5215457 | MDS-6EX RAMP ASSEMBLY | 2 | F |
| 2 | 5505350 | MODEL #211 THAIR PIN/ LARGE | 8 | A |
| 3 | 5250031 | MDS-6KF PARTS BOX | 1 | D |
| 4 | 5215424 | POWER UNIT CONSOLE ASSEMBLY, SHORT | 1 | D |
| 5 | 5905940 | PRODUCT DATA LABEL | 1 | A |
| 6 | 5905631 | MDS-6K CONSOLE PANEL WARNING LABEL | 1 | A |
| 7 | 5905179 | WARNING/CRUSH POINT LABEL | 4 | --- |
| 8 | 5905178 | WARNING/LUBE POINT LABEL | 4 | --- |
| 9 | 5905307 | CAUTION CAPACITY SCISSOR LIFT | 4 | --- |
| 10 | 5905308 | MDS-6K CAPACITY LABEL | 4 | --- |
| 11 | 5905204 | BENDPAK LABEL | 4 | --- |
| 12 | 5905176 | WARNING TO PROLONG LIFE | 2 | --- |
| 13 | 5900147 | SAFETY MANUAL ALL / SM 93-1 | 1 | --- |
| 14 | 5900152 | ALIGN OIM OPERATION INSPECTION & MAINTENANCE | 1 | --- |
| 15 | 5900280 | ALI/LP FRAME ENGAGING LIFTS GUIDE | 1 | --- |
| 16 | 5905151 | SAFETY TIPS CARD ALI-ST 90 | 1 | --- |
| 17 | 5905465 | MANUFACTURER LABEL | 1 | --- |
| 18 | 5930629 | MDS-6K WARNING DRIVE OVER LABEL | 1 | --- |
| 19 | 5905951 | 5905951-2015_Serial_Tag-B | 1 | --- |

| | | | | |
|--|----|------------|--------------|---|
| DRAWN | TM | 01/26/2016 | | 1645 LEMONWOOD DR. SANTA PAULA, CA 93060 |
| CHECKED | D8 | 12/20/2016 | | |
| THIRD ANGLE PROJECTION | | | | |
| | | | | |
| TITLE: MDS-6EX MDS-6LPF PRODUCTION LIFT VER B | | | | |
| SIZE DWG. NO. | | | REV | |
| A 5261001 | | | C | |
| SCALE: 1:30 | | | SHEET 1 OF 3 | |

PROPRIETARY AND CONFIDENTIAL
 THE INFORMATION CONTAINED IN THIS DRAWING IS THE PROPERTY OF BENDPAK INC. ANY REPRODUCTION IN PART OR AS A WHOLE WITHOUT THE WRITTEN PERMISSION OF BENDPAK INC. IS PROHIBITED.

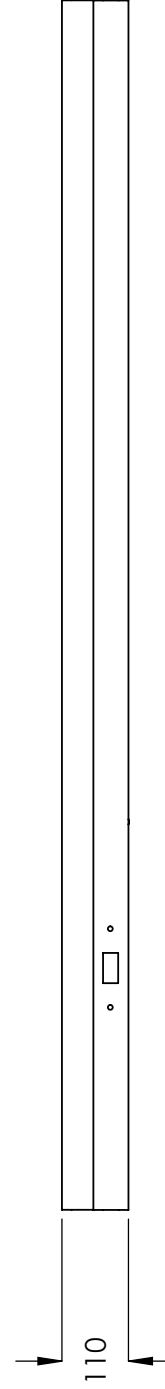
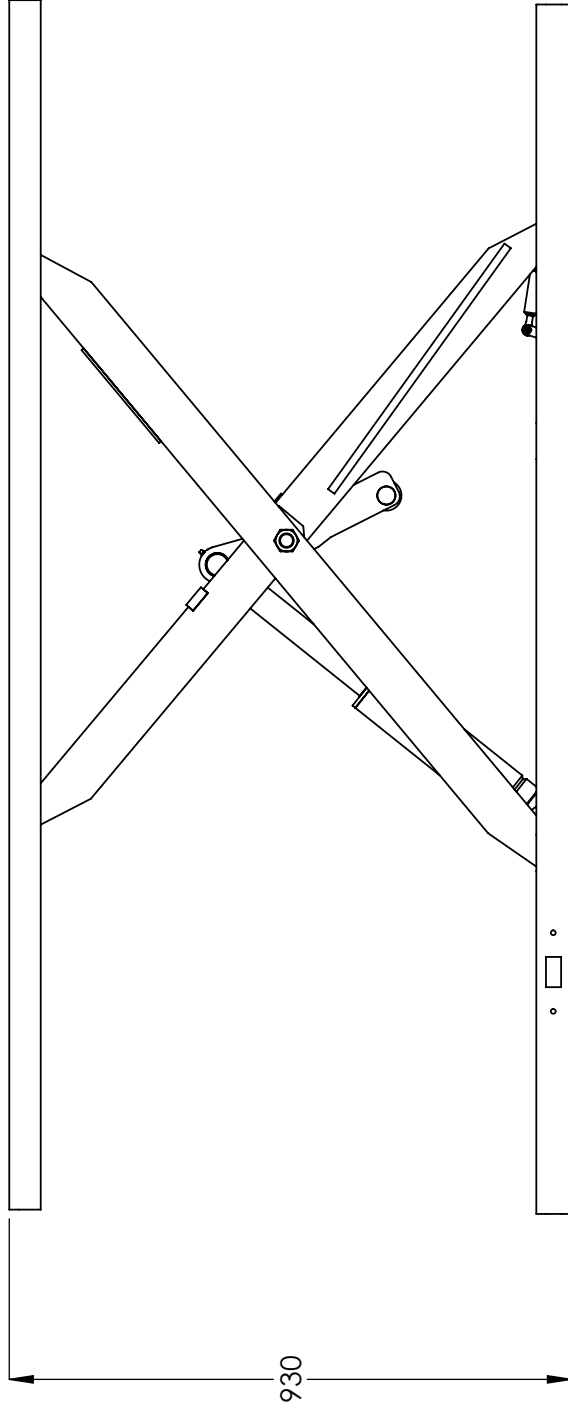



BendPak 1645 LEMONWOOD DR.
SANTA PAULA, CA 93060

TITLE: MDS-6EXTF, MDS-6LPF
Side View

| | | |
|----------|----------|-----|
| SIZE | DWG. NO. | REV |
| A | 5261001 | C |

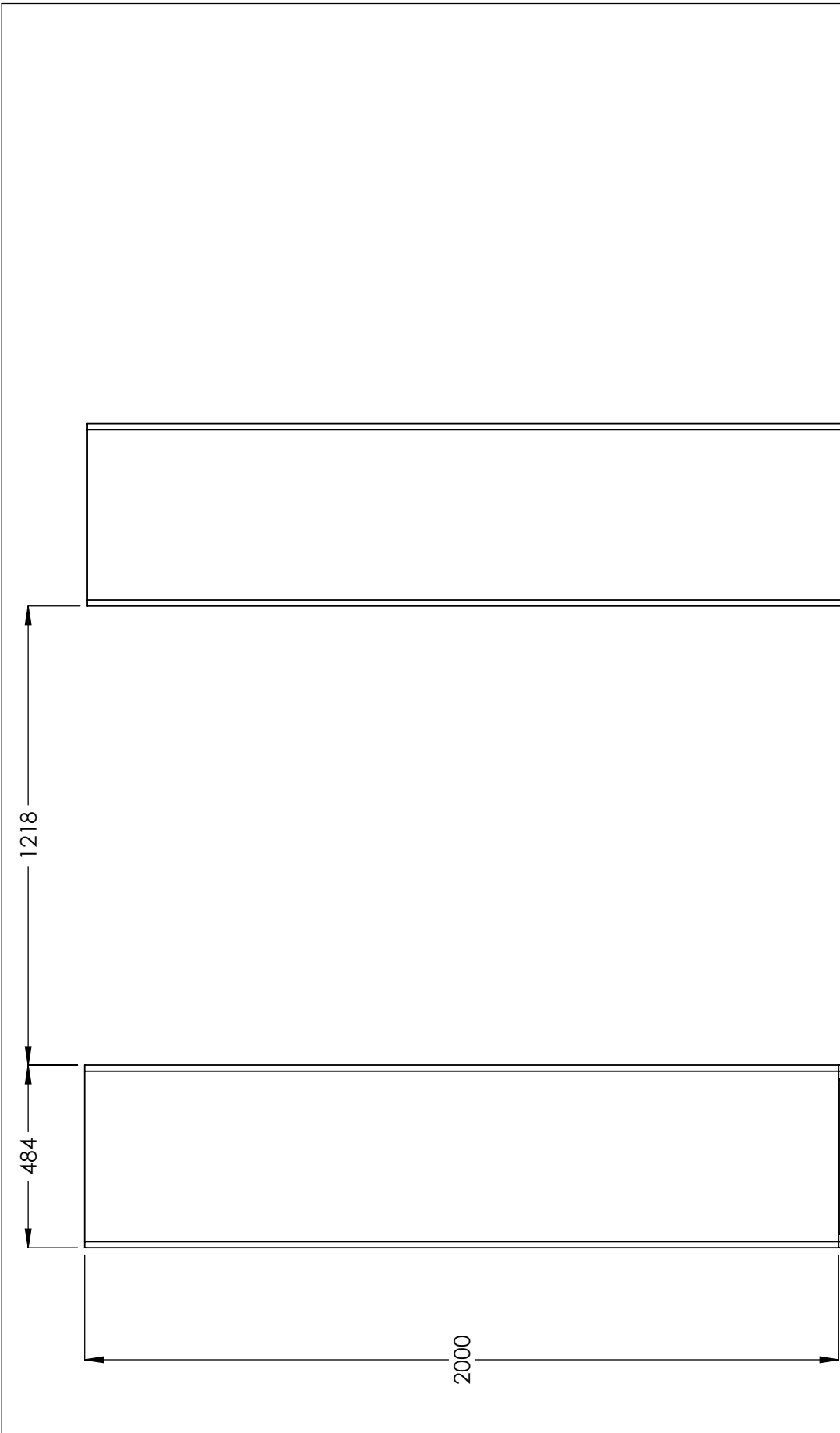
SCALE: 1:12 SHEET 2 OF 3



| | |
|---|-----|
|  1645 LEMONWOOD DR. SANTA PAULA, CA 93060 | |
| TITLE: MDS-6EXTF, MDS-6LPF Ramp Spacing | |
| SIZE DWG. NO. | REV |
| A 5261001 | C |
| SCALE: 1:15 | |
| SHEET 3 OF 3 | |

| REV | DESCRIPTION | DATE | EDITED BY | ECO# |
|-----|---|------------|-----------|-------|
| B | REPLACED 5550106 WITH 5550087, REPLACED 5550487 WITH 5550001, ADDED (2) 5550001 AND 5550395, UPDATED BOM REVISIONS AND NEXT ASSEMBLY | 04/15/2016 | TM | 00746 |
| C | REPLACED 5530050 WITH 5530304, REPLACED 5550480 WITH 5550486, ADDED 5550142, ADDED 5550106, ADDED 5600872, ADDED 5540113, ADDED 5746318 | 10/05/2016 | TS | 00781 |
| D | REMOVED 5570060, UPDATED BOM REVISIONS | 12/09/2016 | TS | 00794 |

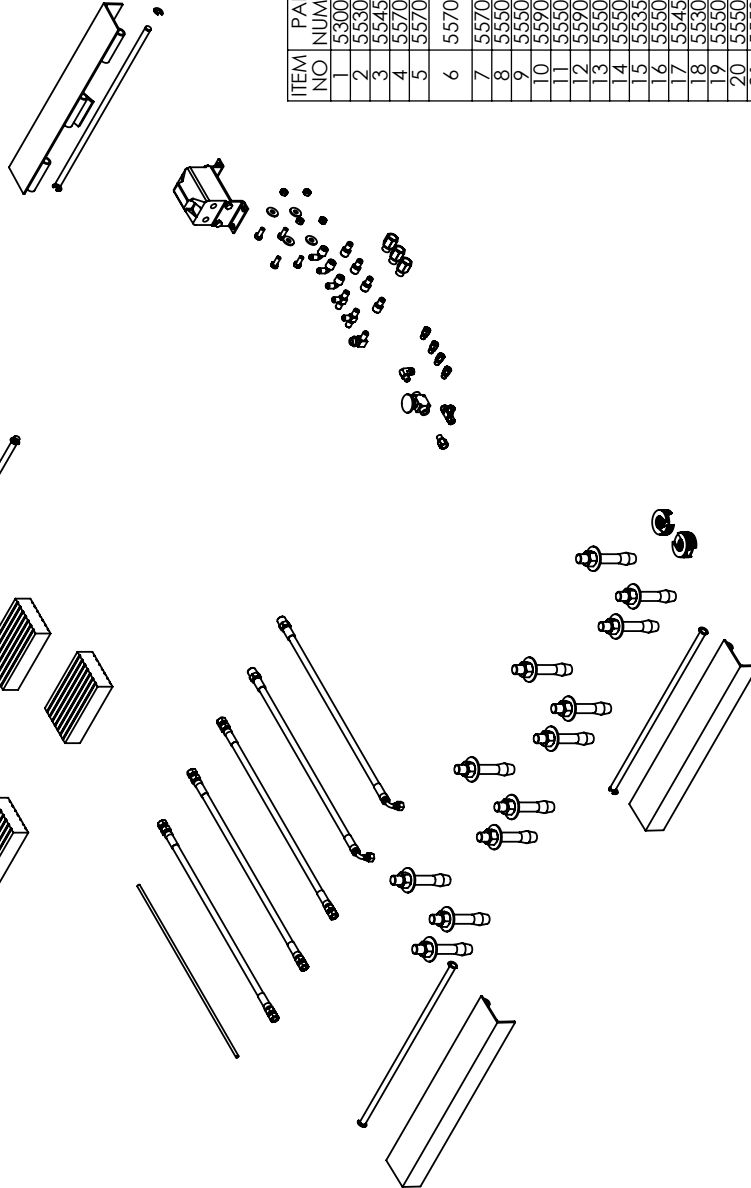

| ITEM NO | PART NUMBER | DESCRIPTION | QTY | REV |
|---------|-------------|--|---------|-----|
| 1 | 5300845 | LR-60/60P, P-6 38mm (1.5") RUBBER PAD | 4 | A |
| 2 | 5530456 | AB 3/4" x 4 - 3/4" | 12 | -- |
| 3 | 5545535 | C WASHER SHIM FOR LIFTS | 20 | -- |
| 4 | 5570061 | MDS-6K/KF HYDRAULIC HOSE ASSY Ø6.35 x 1.676mm SB | 2 | B |
| 5 | 5570062 | MDS-6K/KF HYDRAULIC HOSE ASSY Ø6.35 x 7.62mm DS | 1 | A |
| 6 | 5570176 | MDS-6K, XPR-9D/10 HYDRAULIC HOSE ASSY Ø6.35 x 330mm DS | 2 | E |
| 7 | 5570795 | 1/4" POLY-FLO TUBING | 9144mm* | -- |
| 8 | 5550103 | FIG ELB-04 JIC-06 ORB | 1 | -- |
| 9 | 5550310 | FIG TEE-04 JIC-04 JIC | 2 | -- |
| 10 | 5590135 | HYDRAULIC FLOW DIVIDER | 1 | A |
| 11 | 5550493 | FIG RST-04 JIC x-06 NPT x-.062 ID | 4 | -- |
| 12 | 5590175 | PUSH BUTTON AIR VALVE | 1 | -- |
| 13 | 5550486 | FIG NPL-02 NPT x-04 F NPT | 1 | -- |
| 14 | 5550087 | FIG ELB-04 COMP x-02 NPT | 1 | -- |
| 15 | 5535001 | NUT M8 x 1.25 NL | 4 | -- |
| 16 | 5550001 | FIG NPL-04 COMP x-02 NPT | 4 | -- |
| 17 | 5545340 | WASHER M8 x24 FLAT | 4 | -- |
| 18 | 5530304 | HHB M8 x 1.25 x 20 | 4 | A |
| 19 | 5550395 | FIG TEE-04 COMP x-04 COMP x-04 COMP | 1 | -- |
| 20 | 5550142 | FIG NPL-06 ORB x-06 F NPT | 3 | -- |
| 21 | 5550106 | FIG ELB-04 JIC-06 NPT | 3 | A |
| 22 | 5746318 | MDS-6K DRIVE UP RAMP PIN | 4 | A |
| 23 | 5540113 | F RING Ø1 1/2" OD TRUARC 5133-50 | 8 | A |
| 24 | 5600872 | MDS-6KF FLUSH HINGE COVER WELDMENT | 4 | D |

| | | |
|---|----------|--------------|
| DRAWN | TM | 09/18/2014 |
| CHECKED | | |
| THIRD ANGLE PROJECTION | | |
| | | |
| PROPRIETARY AND CONFIDENTIAL THE INFORMATION CONTAINED HEREIN IS THE SOLE PROPERTY OF BENDPAK INC. ANY REPRODUCTION OR TRANSMISSION WITHOUT THE WRITTEN PERMISSION OF BENDPAK INC. IS PROHIBITED. | | |
| TITLE: MDS-6KLF PARTS BOX MDS-6KLF PARTS BOX | | |
| SIZE | DWG. NO. | REV |
| A | 5250031 | D |
| SCALE: 1:15 | | SHEET 1 OF 2 |

BendPak 1645 LEMONWOOD DR. SANTA PAULA, CA 93060

BendPak 1645 LEMONWOOD DR.
SANTA PAULA, CA 93060

TITLE: MDS-6EXTF, MDS-6LPF
Parts Box

SIZE DWG. NO. **A** 5250031 REV **D**

SCALE: 1:10

SHEET 2 OF 2

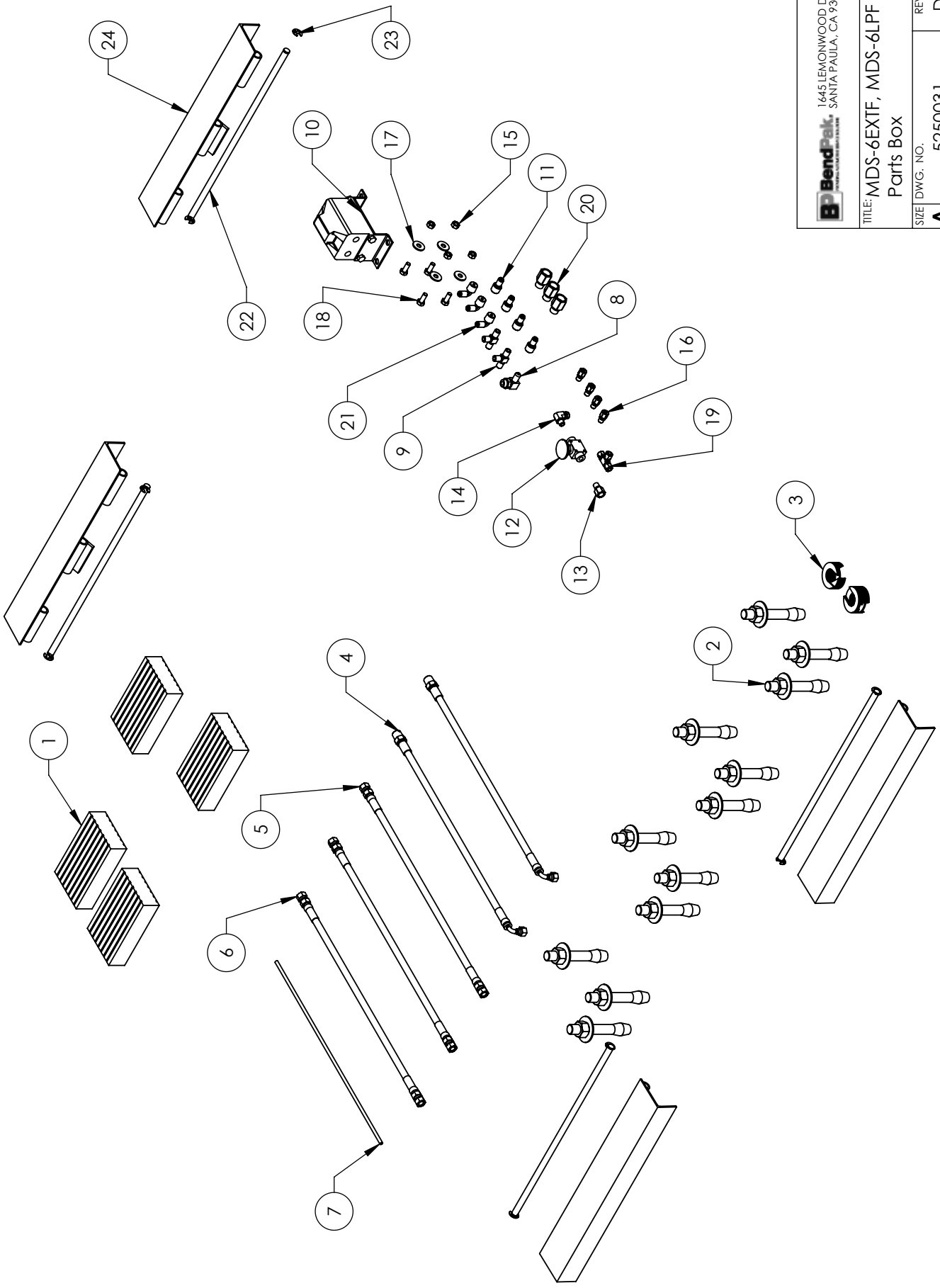

BP BendPak.

R Ranger.